

# HAFCO METALMASTER

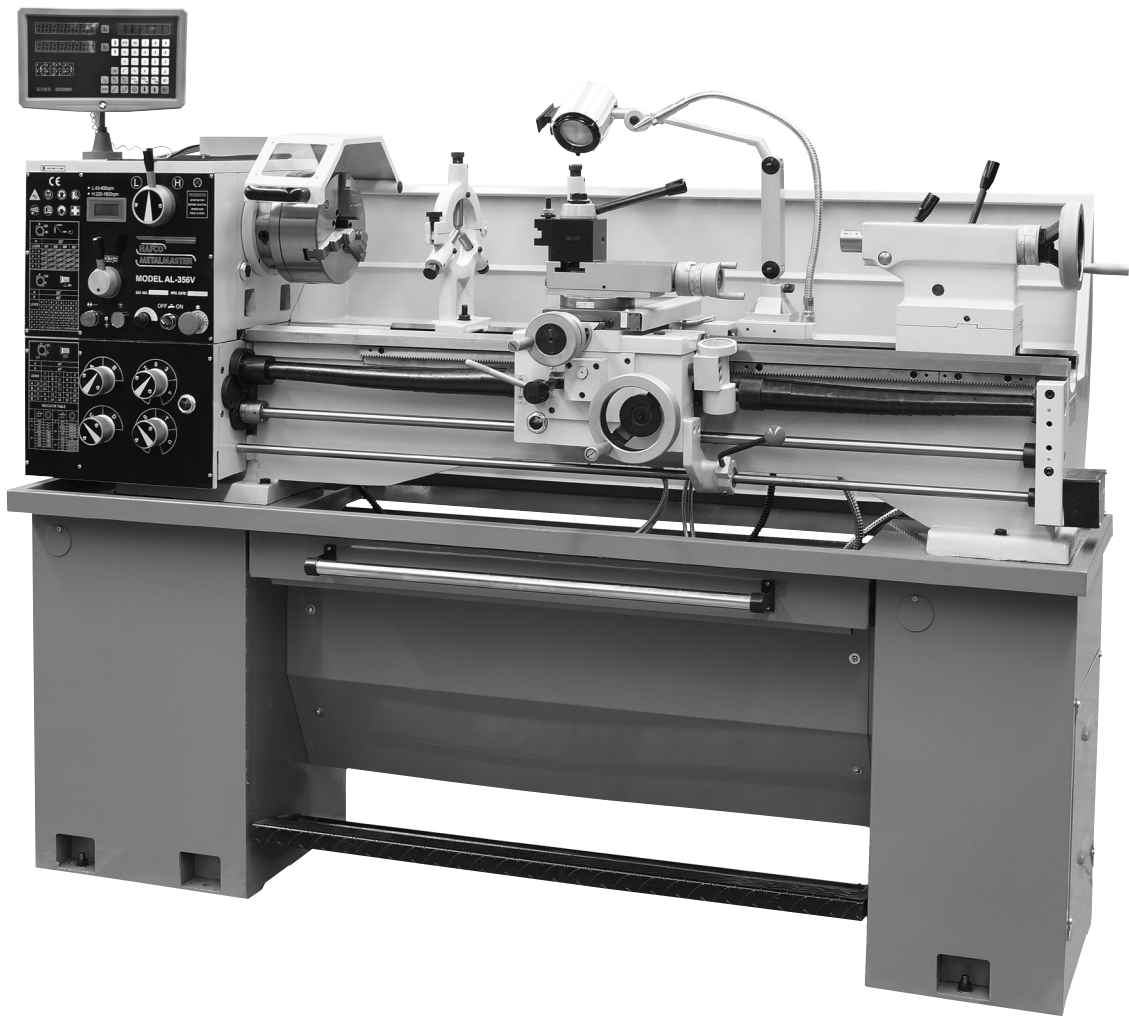

Edition : 2.0  
Date: (08/25)

## Instruction Manual

# CENTRE LATHE AL-356V

Order Code: (L565D)

**MACHINE DETAILS**

<b>MACHINE.</b>	CENTRE LATHE
<b>MODEL NO.</b>	AL-356V
<b>SERIAL NO.</b>	
<b>DATE OF MANF.</b>	

IMPORTED BY

AUSTRALIA



[www.machineryhouse.com.au](http://www.machineryhouse.com.au)

NEW ZEALAND



[www.machineryhouse.co.nz](http://www.machineryhouse.co.nz)

**NOTE:**

*This manual is only for your reference. At the time of the compiling of this manual every effort to be exact with the instructions, specifications, drawings, and photographs of the machine was taken. Owing to the continuous improvement of the HAFCO METALMASTER machine, changes may be made at any time without obligation or notice. Please ensure the local voltage is the same as listed on the specification plate before operating any electric machine.*

**SAFETY SYMBOLS:**

*The purpose of safety symbols is to attract your attention to possible hazardous conditions*



**WARNING** Indicates a potentially hazardous situation causing injury or death



**CAUTION** Indicates an alert against unsafe practices.

**Note:** Used to alert the user to useful information



**NOTE:**

*In order to see the type and model of the machine, please see the specification plate. Usually found on the back of the machine. See example (Fig.1)*

Fig.1

<b>HAFCO</b> <b>METALMASTER</b>	
<b>PRODUCT SPECIFICATIONS</b>	
Model: AL-356V	Voltage: 240V/50Hz
Capacity: 356x1000mm	Motor: 1.5kW
Nett Weight: 650kg	FLC: 5.7A
MFG Date:	
<b>Serial No:</b>	
Imported by <a href="http://www.machineryhouse.com.au">www.machineryhouse.com.au</a>	Made in China <a href="http://www.machineryhouse.co.nz">www.machineryhouse.co.nz</a>



**CONTENTS:**

**1. GENERAL MACHINE INFORMATION**

1.1 Specifications ..... 4  
1.2 Identification ..... 5

**2. SAFETY**

2.1 General Metalworking Machine Safety ..... 6  
2.2 Specific Safety For Lathes ..... 9

**3. POWER SUPPLY**

3.1 Electrical Installation ..... 10  
3.2 Full Load Current ..... 10

**4. SETUP**

4.1 Unpacking ..... 11  
4.2 Included Accessories ..... 11  
4.3 Clean Up ..... 11  
4.4 Site Preparation ..... 11  
4.5 Lifting Instructions ..... 12  
4.6 Anchoring To The Floor ..... 13  
4.7 Machine Levelling ..... 13  
4.8 Assembly ..... 14

**5. OPERATION**

5.1 Controls ..... 15  
5.2 Chuck and Faceplate Mounting ..... 19  
5.3 Setting Cutting Tool To Spindle Centerline... 21  
5.4 Spindle Speeds ..... 22  
5.5 Threading ..... 23  
5.6 Change Gears ..... 26  
5.7 Selecting The Feeds ..... 27  
5.8 Quick Change Toolpost ..... 28  
5.9 Aligning Tailstock to Spindle Centerline..... 29  
5.10 Removing & Replacing The Bed Gap ..... 30  
5.11 Spindle Spider ..... 30  
5.12 Coolant System ..... 31

**6. MAINTENANCE**

6.1 Lubrication ..... 32  
6.2 Lubrication Points ..... 33  
6.3 Troubleshooting ..... 36  
6.4 Adjustments ..... 37  
    Slide Way Gibs ..... 37  
    Cross Slide Nut ..... 38  
    Feed Clutch ..... 38  
    V-Belts ..... 39  
    Half Nut ..... 39

**SPARE PARTS**

Bed Assembly 1 Diagram ..... 41  
Bed Assembly 1 Parts List ..... 42  
Bed Assembly 2 Diagram ..... 44  
Bed Assembly 2 Parts List ..... 45  
Bed Assembly 3 Diagram ..... 46  
Bed Assembly 3 Parts List ..... 47  
Headstock 1 Diagram ..... 48  
Headstock 1 Parts List ..... 49  
Headstock 2 Diagram ..... 51  
Headstock 2 Parts List ..... 52  
Headstock 3 Diagram ..... 53  
Headstock 3 Parts List ..... 54  
Gearbox 1 Parts Diagram ..... 55  
Gearbox 2 Parts Diagram ..... 56  
Gearbox Parts List ..... 57  
Apron Diagram ..... 59  
Apron Parts List ..... 60  
Cross Slide Diagram & Parts List ..... 62  
Cross Slide 2 Diagram & Parts List ..... 64  
Top Slide Diagram & Parts List ..... 66  
Tailstock Assembly Diagram & Parts List ..... 68  
Steadies Diagram & Parts Lists ..... 70  
Coolant Sys. & Lamp Diagram & Parts List ..... 72  
Electrical Assembly 2 Diagram ..... 74  
Electrical Assembly Parts List ..... 75  
Chuck Safety Guard Diagram & Parts List ..... 76  
Leadscrew Cover Diagram & Parts List ..... 77  
Feed Rod Clutch Diagram & Parts List ..... 78  
Bed Stop Diagram & Parts List ..... 79

## 1.1 SPECIFICATIONS

Order Code	L565D
<b>MODEL</b>	<b>AL-356V</b>
Swing Over Bed (mm)	356
Distance Between Centres (mm)	1000
Spindle Bore (mm)	51
Swing In Gap (mm)	476
Swing Over Cross-slide (mm)	224
Digital Readout System Fitted	Yes
Quick Change Toolpost Fitted	Yes
Tool Height To Suit (mm)	16
Centre Height (mm)	178
Spindle Nose Size or Type Camlock	D1-5
Bed Width (mm)	187
Headstock Spindle Taper (MT)	6
Tailstock Taper (MT)	4
Cross Slide Travel (mm)	160
Compound Slide Travel (mm)	68
Leadscrew Type	Metric
Imperial Cross Feed (X-Axis) (mm/rev)	0.022 / 0.298
Imperial Longitudinal Feed (Z-Axis) (mm / rev)	0.078 / 1.044
Metric Thread Steps & Pitch (No / mm)	36 (0.45 - 10)
Imperial Thread Steps & TPI (No / TPI)	20 (2-1/4 - 40)
3 Jaw Chuck Diameter (mm)	200
4 Jaw Chuck Diameter (mm)	200
Spindle Steps / Speeds (No / rpm)	Variable (40 - 1800)
Motor Power (kW / hp)	1.5 / 2
Voltage / Amperage (v / amp)	240 / 10
Dimensions (L x W x H) (mm)	1870 x 740 x 1785
Nett Weight (kg)	650

## 1.2 IDENTIFICATION

Become familiar with the names and locations of the controls and features shown below to better understand the instructions when mentioned later in this manual.

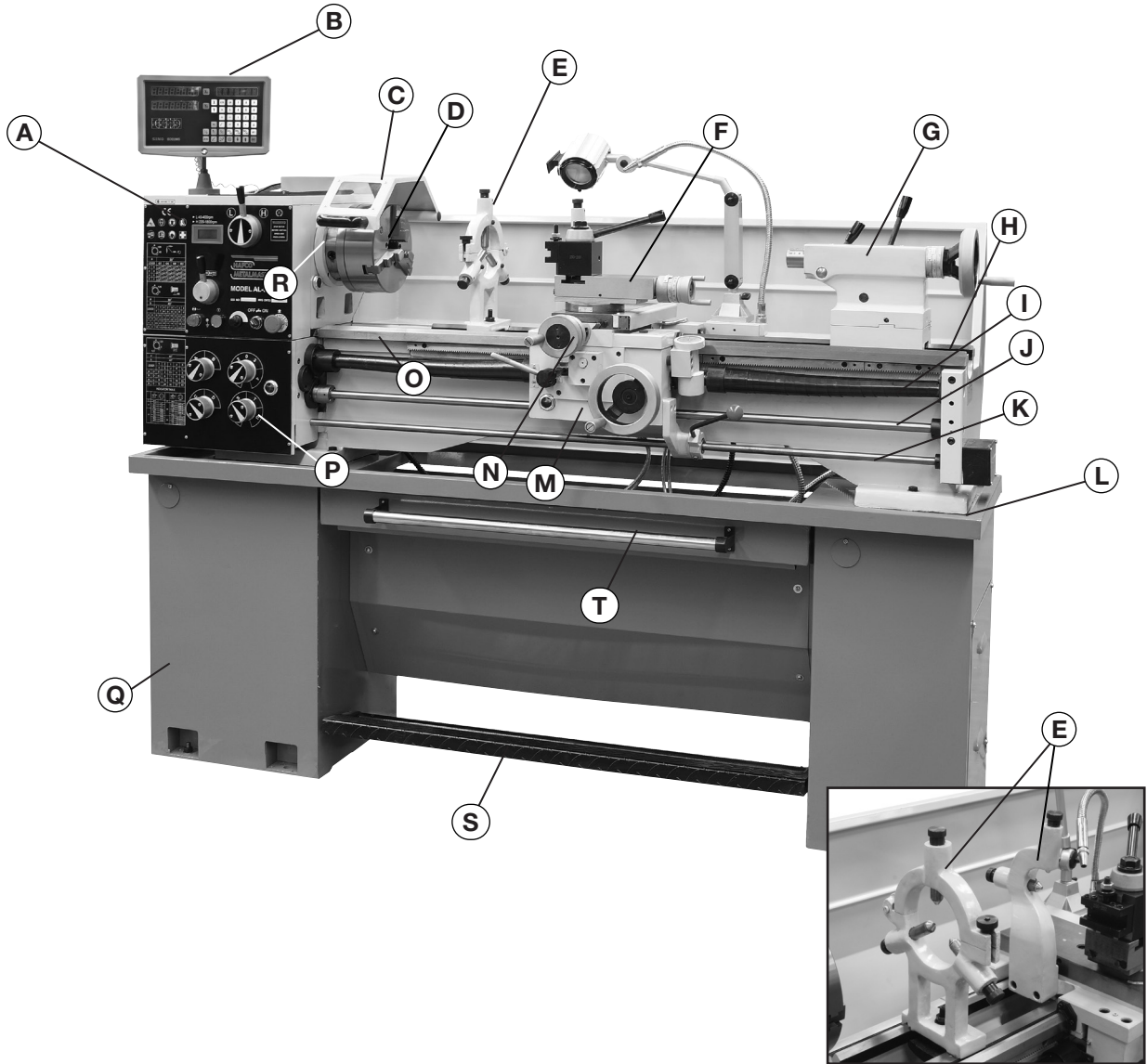

<b>A</b>	Headstock	<b>K</b>	Start and Stop Shaft
<b>B</b>	Haeco Digital Readout Display	<b>L</b>	Swarf Tray
<b>C</b>	Chuck Safety Guard	<b>M</b>	Saddle
<b>D</b>	3 Jaw Chuck	<b>N</b>	Cross Slide
<b>E</b>	Fixed & Travelling Steadies	<b>O</b>	Bed Gap
<b>F</b>	Top Slide	<b>P</b>	Feed Gearbox
<b>G</b>	Tailstock	<b>Q</b>	Stand
<b>H</b>	Bed	<b>R</b>	Spindle
<b>I</b>	Leadscrew	<b>S</b>	Foot Brake
<b>J</b>	Feed Shaft	<b>T</b>	Slideout Swarf Tray

## 2. SAFETY

### 2.1 GENERAL METALWORKING MACHINE SAFETY

DO NOT use this machine unless you have read this manual or have been instructed in the use of this machine in its safe use and operation.



## WARNING!

This manual provides safety instructions on the proper setup, operation, maintenance, and service of this machine. Save this manual, refer to it often, and use it to instruct other operators.

Failure to read, understand and follow the instructions in this manual may result in fire or serious personal injury, including amputation, electrocution, or death.

The owner of this machine is solely responsible for its safe use. This responsibility includes, but is not limited to proper installation in a safe environment, personnel training and authorization to use, proper inspection and maintenance, manual availability and comprehension, of the application of the safety devices, integrity, and the use of personal protective equipment.

The manufacturer will not be held liable for injury or property damage from negligence, improper training, machine modifications or misuse.



- ✓ Always wear safety glasses or goggles.
- ✓ Wear appropriate safety footwear.
- ✓ Wear respiratory protection where required.
- ✓ Gloves should never be worn while operating the machine, and only worn when handling the work piece.
- ✓ Wear hearing protection in areas > 85 dBA. If you have trouble hearing someone speak from one metre (three feet) away, the noise level from the machine may be hazardous.
- ✓ DISCONNECT THE MACHINE FROM POWER when making adjustments or servicing.
- ✓ Check and adjust all safety devices before each job.
- ✓ Ensure that guards are in position and in good working condition before operating.
- ✓ Ensure that all stationary equipment is anchored securely to the floor.
- ✓ Ensure all machines have a start/stop button within easy reach of the operator.
- ✓ Each machine should have only one operator at a time. However, everyone should know how to stop the machine in an emergency.

## 2.1 GENERAL SAFETY REQUIREMENTS CONT.

- ✓ Ensure that keys and adjusting wrenches have been removed from the machine before turning on the power. Appropriate storage for tooling should be provided.
- ✓ Ensure that all cutting tools and blades are clean and sharp. They should be able to cut freely without being forced.
- ✓ Stop the machine before measuring, cleaning or making any adjustments.
- ✓ Wait until the machine has stopped running to clear cuttings with a vacuum, brush or rake.
- ✓ Keep hands away from the cutting head and all moving parts.
- ✓ Avoid awkward operations and hand positions. A sudden slip could cause the hand to move into the cutting tool or blade.
- ✓ Return all portable tooling to their proper storage place after use.
- ✓ Clean all tools after use.
- ✓ Keep work area clean. Floors should be level and have a non-slip surface.
- ✓ Use good lighting so that the work piece, cutting blades, and machine controls can be seen clearly. Position any shade lighting sources so that they do not cause any glare or reflections.
- ✓ Ensure there is enough room around the machine to do the job safely.
- ✓ Obtain first aid immediately for all injuries.
- ✓ Understand that the health and fire hazards can vary from material to material. Make sure all appropriate precautions are taken.
- ✓ Clean machines and the surrounding area when the operation is finished.
- ✓ Use proper lock out procedures when servicing or cleaning the machines or power tools.

### DO NOT

- × Do not distract an operator. Horseplay can lead to injuries and should be strictly prohibited.
- × Do not wear loose clothing, gloves, neckties, rings, bracelets or other jewellery that can become entangled in moving parts. Confine long hair.
- × Do not handle cuttings by hand because they are very sharp. Do not free a stalled cutter without turning the power off first. Do not clean hands with cutting fluids.
- × Do not use rags or wear gloves near moving parts of machines.
- × Do not use compressed air to blow debris from machines or to clean dirt from clothes.
- × Do not force the machine. It will do the job safer and better at the rate for which it was designed.



### **CAUTION!**

***It is impossible to cover all possible hazards Every workshop environment is different. These are designed as a guide to be used to compliment training and as a reminder to users prior to equipment use. Always consider safety first, as it applies to the individual working conditions.***



### **WARNING!**

***Before operating any machine, take time to read and understand all safety signs and symbols. If not understood seek explanation from your supervisor or an experienced operator.***

## 2.1 GENERAL SAFETY REQUIREMENTS Cont.

**HAZARDS ASSOCIATED WITH MACHINES** include, but are not limited to:

- Being struck by ejected parts of the machinery.
- Being struck by material ejected from the machinery.
- Contact or entanglement with the machinery.
- Contact or entanglement with any material in motion.

**Health Hazards** (other than physical injury caused by moving parts)

- Chemicals hazards that can irritate, burn, or pass through the skin.
- Airborne items that can be inhaled, such as oil mist, metal fumes, solvents, and dust.
- Heat, noise, and vibration.
- Ionizing or non-ionizing radiation. (X-ray, lasers, etc.)
- Biological contamination and waste.
- Soft tissue injuries (for example, to the hands, arms, shoulders, back, or neck) resulting from repetitive motion, awkward posture, extended lifting, and pressure grip.

**Other Hazards**

- Slips and falls from and around machinery during maintenance.
- Unstable equipment that is not secured against falling over.
- Safe access to/from machines. (access, egress)
- Fire or explosion.
- Pressure injection injuries from the release of fluids and gases under high pressure.
- Electrical Hazards, such as electrocution from faulty or ungrounded electrical components.
- Environment in which the machine is used. (in a machine shop, or on a work site)



### **WARNING!**

*The machine is the sole responsibility of the owner for its safe use. This responsibility includes but is not limited to proper installation in a safe environment, personnel training, proper inspection and maintenance, manual availability and comprehension. The manufacturer will not be held liable for injury or property damage from negligence, improper training, machine modifications or misuse.*



### **WARNING!**

*Machines are safeguarded to protect the operator from injury or death with the placement of guards. Machines must not be operated with the guards removed or damaged.*

## 2.2 SPECIFIC LATHE SAFETY

**DO NOT use this machine unless you have been instructed in its safe use and operation and have read and understood this manual**



*Safety glasses must be worn at all times in work areas*



*Long and loose hair must be contained*



*Gloves must not be worn when using this machine*



*Sturdy footwear must be worn at all times in work areas*



*Close fitting/protective clothing must be worn*



*Rings and jewelry must not be worn.*

### PRE-OPERATIONAL SAFETY CHECKS

- ✓ Locate and ensure you are familiar with all machine operations and controls.
- ✓ Ensure all guards are fitted, secure and functional. Do not operate if guards are missing or faulty.
- ✓ Check workspaces and walkways to ensure no slip/trip hazards are present.
- ✓ Check the job is clamped tight in the chuck.
- ✓ Remove all tools from the bed and slides of the machine.
- ✓ Ensure the correct speed for machining process is selected.
- ✓ Remove the chuck key before starting the lathe.

### OPERATIONAL SAFETY CHECKS

- ✓ Before making adjustments or measurements, switch off and bring the machine to a complete standstill.
- ✓ Always remove the chuck key from the chuck.

### ENDING OPERATIONS AND CLEANING UP

- ✓ Switch off the machine when work completed.
- ✓ Reset all guards to a fully closed position.
- ✓ Avoid letting swarf build up on the tool or job. Stop the machine and remove it.
- ✓ Leave the machine in a safe, clean and tidy state.

### DON'T

- × **Do not** use faulty equipment. Immediately report suspect machinery.
- × **Do not** try to lift chucks or face plates that are too heavy for you.
- × **Do not** leave the machine running unattended.
- × **Do not** attempt to slow or stop the chuck or revolving work by hand.
- × **Do not** leave equipment on top of the machine.

### POTENTIAL HAZARDS AND INJURIES

- Flying objects such as the chuck key left in chuck.
- Cutting tool injury when cleaning, filing or polishing.
- Hair/clothing getting caught in moving machine parts.
- Metal splinters and swarf.
- Eye Injuries.

### 3. POWER SUPPLY

#### 3.1 ELECTRICAL INSTALLATION

Place the machine near an existing power source. Make sure all power cords are protected from traffic, material handling, moisture, chemicals, or other hazards. Make sure there is access to a means of disconnecting the power source. The electrical circuit must meet the requirements for 415V.

**NOTE : The use of an extension cord is not recommended as it may decrease the life of electrical components on your machine.**

#### ELECTRICAL REQUIREMENTS

Nominal Voltage.....	240V
Cycle.....	50 Hz
Phase.....	Single Phase
Power Supply Circuit.....	10 Amps
Full Load Current.....	5.7 Amps

(Full load current rating is also on the specification plate on the motor.)

#### 3.2 FULL-LOAD CURRENT RATING

The full-load current rating is the amperage a machine draws when running at 100% of the output power. Where machines have more than one motor, the full load current is the amperage drawn by the largest motor or a total of all the motors and electrical devices that might operate at one time during normal operations.

Full-Load Current Rating for these machine at 240V is 5.7 Amps

It should be noted that the full-load current is not the maximum amount of amps that the machine will draw. If the machine is overloaded, it will draw additional amps beyond the full-load rating and if the machine is overloaded for a long period of time, damage, overheating, or fire may be caused to the motor and circuitry.

This is especially true if connected to an undersized circuit or a long extension lead. To reduce the risk of these hazards, avoid overloading the machine during operation and make sure it is connected to a power supply circuit that meets the requirements.



## 4 SETUP

### 4.1 UNPACKING

This machine was carefully packaged for safe transport. When unpacking, separate all enclosed items from packaging materials and inspect them for shipping damage. If items are damaged, please contact your distributor.

**NOTE: Save all the packaging materials until you are completely satisfied with the machine and have resolved any issues with the distributor, or the shipping agent.**

When unpacking, check the packing list to make sure that all parts shown are included. If any parts are missing or broken, please contact your distributor.

### 4.2 INCLUDED ACCESSORIES

200mm 3-jaw chuck with reverse jaws  
200mm 4-jaw chuck  
Face plate  
Fixed and travelling steadies  
Change gears  
Dead centre  
Cabinet stand  
Splash tray

Toolbox and instruction booklet  
Swarf tray  
Thread-chasing dial  
Chuck guard  
2 Axis Digital Readout  
Leadscrew Covers  
Quick Change Toolpost  
Work Light

### 4.3 CLEAN - UP

The unpainted surfaces of the machine have been coated with a waxy oil to protect them from corrosion during shipment. Remove the protective coating with a solvent cleaner or a citrus based degreaser.

Optimum performance from your machine will be achieved when you clean all moving parts or sliding contact surfaces that are coated with rust prevented products.

It is advised to avoid chlorine based solvents, such as acetone or brake parts cleaner, as they will damage painted surfaces and strip metal should they come in contact. Always follow the manufacturer's instructions when using any type of cleaning product.

### 4.4 SITE PREPARATION

When selecting the site for the machine, consider the largest size of workpiece that will be processed through the machine and provide enough space around the machine for operating the machine safely. Consideration should be given to the installation of auxiliary equipment.

Leave enough space around the machine to open or remove doors/covers as required for the maintenance and service as described in this manual.

It is recommended that the machine is anchored to the floor to prevent tipping or shifting. It also reduces vibration that may occur during operation.

## 4.5 LIFTING INSTRUCTIONS

On the day that the machine arrives, make sure that a crane or forklift with sufficient capacity is available to unload the machine from the vehicle. Ensure access to the chosen site is clear and that doors and ceilings are sufficiently high and wide enough to receive the machine.

To handle the machine, the slings should be positioned so the machine is level when lifted.

### LIFTING POINT

To obtain a balanced condition before lifting, it is necessary to move the tailstock to the right hand end of the bed way and clamp it there. Make sure to clean the bed ways before moving the carriage or tailstock. Use approved webbed slings to lift the lathe as shown in (Fig. 4.1, 4.2). Position the saddle and tailstock along the bed to obtain the balance. Raising and lowering the machine should be done carefully, especially when you are lowering the machine. Be sure not to bump the machine against the floor.

**Important: Do not use slings around the bed as leadscrew and feed shaft may be bent.**

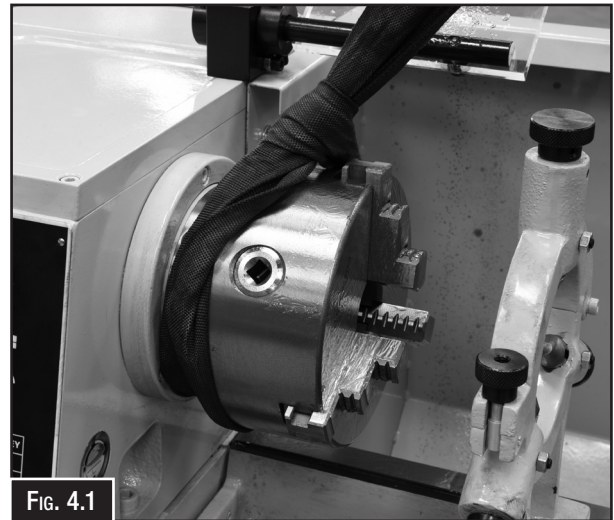

Fig. 4.1

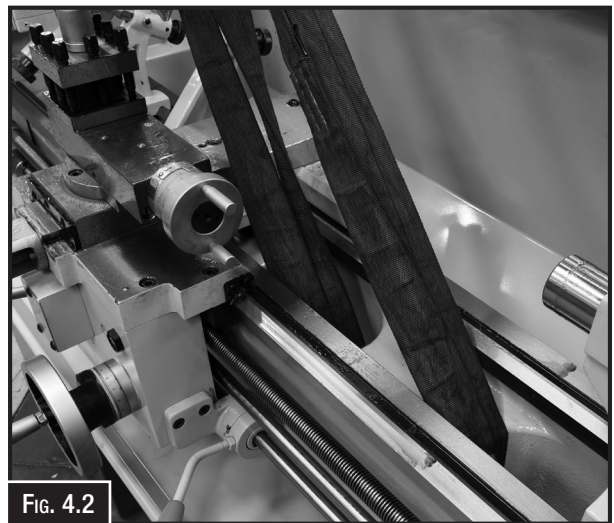

Fig. 4.2

 <b>WARNING</b>	
<b>SAFETY FIRST</b>	<i>The safety instructions given in this manual can not be complete. The environment in every shop is different. Always consider your safety first as it applies to your individual working conditions.</i>
	



### **WARNING!**

***Make sure everyone is away from the load before hoisting. The load must be under control when lowering loads or when the load is suspended. Rigging and crane operation must be carried out by persons with approved qualifications.***

## 4.6 ANCHORING TO THE FLOOR

### OPTIONS FOR MOUNTING

The machine is best mounted on a concrete slab. Masonry anchors with bolts are the best way to anchor machinery, because the anchors sit flush with the floor surface, making it easy to unbolt and move the machine later, if needed. (Fig. 4.3)

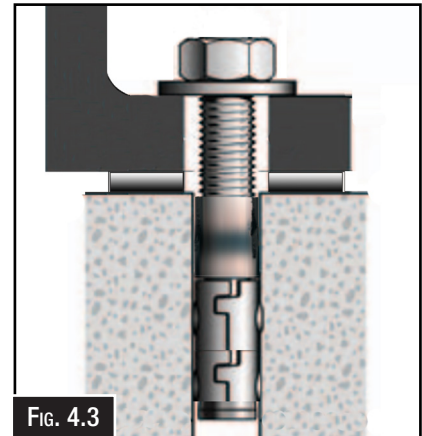

FIG. 4.3

## 4.7 MACHINE LEVELING

To set your machine up so that it operates to optimum performance, apply the following procedure.

After your machine has been anchored to a concrete slab floor, it then needs to be levelled. Loosen the hold down bolts and place a level on the surface of the Lathe bed. Metal shims need to be placed under the corner of the base of the machine until level. Once level and the machine is stable then tighten the hold down bolts. (Fig. 4.4)

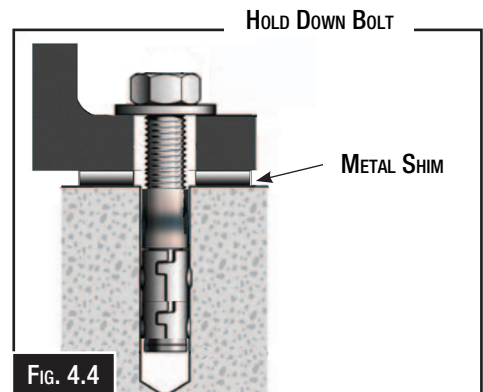
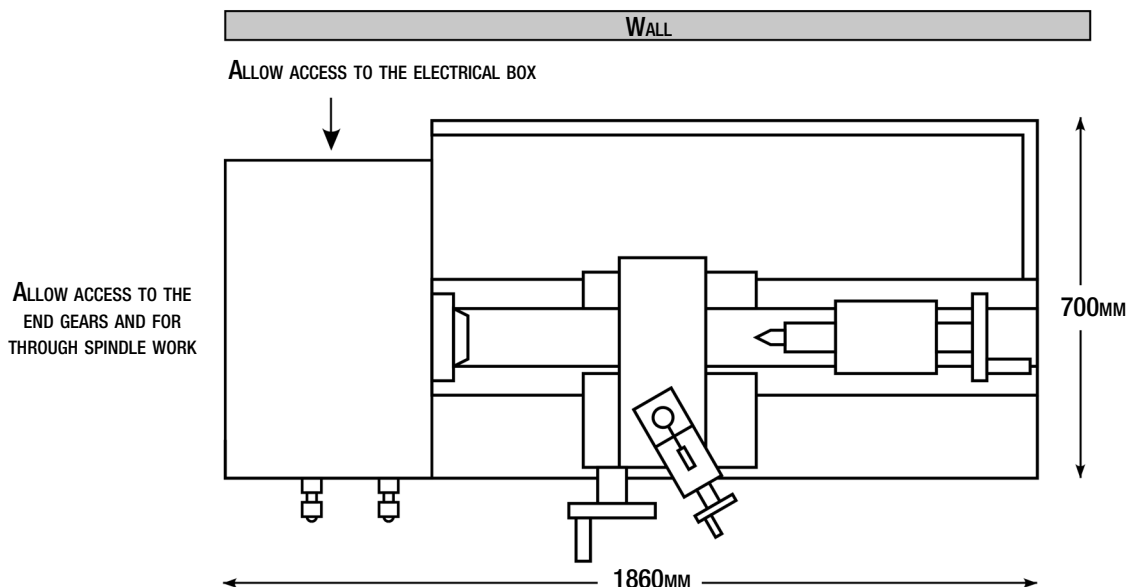

FIG. 4.4

## Floor Plan



## 4.8 ASSEMBLY

The machine must be fully assembled before it can be operated. First clean any parts that are coated in rust preventative to ensure the assembly process can proceed smoothly.

### Mounting The Digital Readout

Disconnect the machine from the power before installing the DRO.

The Digital Readout will need to be fitted using the bracket on the top of the head. (Fig. 4.5)

**NOTE: In some cases the machine may be supplied fully assembled and may only require the fitting of the chuck to the spindle.**



Fig. 4.5

### Assemble Handles.

Assembly required will be the bolting on of the handles. Using a screwdriver assemble each handle on the handwheels of the machine. (Fig. 4.6)

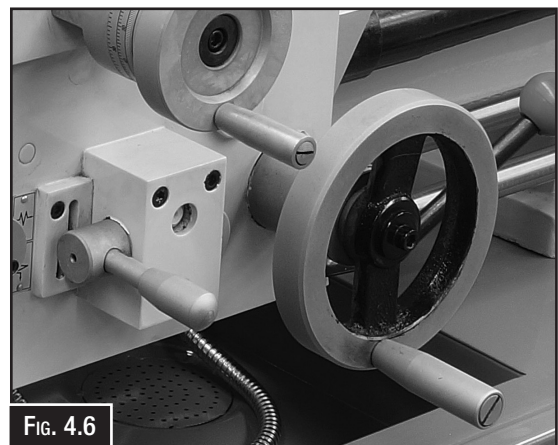
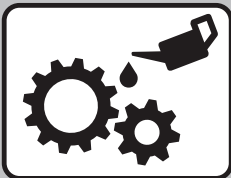

Fig. 4.6

## 4.9 TEST RUN



### **CAUTION!**

**Check the oil levels and lubrication points before running the machine for the first time. Lack of lubrication can cause damage to the machine and may void the warranty.**

Once assembly is complete, test run the machine to ensure it is properly connected to the power and safety components are functioning correctly. Check that the direction of the motor is correct and make sure that the machine rotates in the correct direction.

If the direction is incorrect, isolate the machine and have the electrician make changes to the wiring.

If you find an unusual problem during the test run, immediately stop the machine, disconnect it from power, and fix the problem BEFORE operating the machine again. The Troubleshooting table in the Maintenance section of this manual may be able to help. If the problem persists the contact your dealers service technician.

**To test run the machine:**

1. Connect the machine to the power supply.
2. Make sure that the manual has been read and that the safety instructions at the beginning of the manual are understood. Make sure the machine has been setup correctly
3. Make sure all tools and objects used during set up have been cleared away from the machine.
4. Turn the machine ON.
5. Make sure that the machine is travelling in the correct direction.
6. Listen to and watch for abnormal noises or actions. The machine should run smoothly with little or no vibration or rubbing noises.
7. Any strange or unusual noises should be investigated and corrected before operating the machine again. Always disconnect the machine from power supply when investigating or correcting potential problems. The troubleshooting chart in the maintenance section may be helpful in rectifying a problem.

**Testing The Emergency Stop Button (Fig. 4.7)**

Make sure that the emergency button is working correctly

1. Twist the top of the Emergency Stop button to ensure that it is in the raised position.
2. Start the machine and then press the emergency stop button. The machine should stop and the power should be cut off. If the machine cannot be started then the emergency stop is working correctly.
3. To reset the Emergency Stop twist the red top until it pops up. The machine should now work again.

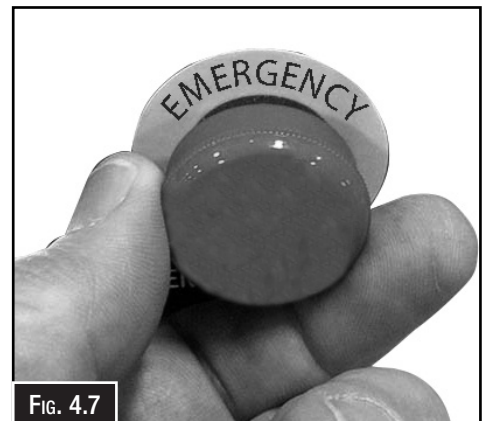

Fig. 4.7

**5. OPERATION**

This machine may perform many types of operations that are beyond the scope of this manual. Many of these operations may be dangerous or deadly if performed incorrectly.

The instructions in this section are written with the understanding that the operator has the necessary knowledge and skills to operate this machine. If at any time you are experiencing difficulties performing any operation, stop using the machine!

If you are an inexperienced operator, we strongly recommend that you read books, trade articles, or seek training from an experienced operator before performing any unfamiliar operations.

**Above all, your safety should come first!**

## 5.1 CONTROLS

The purpose of this control overview is to provide the novice machine operator with a basic understanding of how the machine is used during operation, and the machine controls and what they do. It also helps the operator to understand if they are discussed later in this manual.

**NOTE: DO NOT start the machine until all of the setup instructions have been performed.**

### HEADSTOCK ELECTRICAL CONTROLS (Fig. 5.1)

1. **Pilot Lamp:** Illuminates when power is connected to the control panel.
2. **Jog Button:** Allows for the spindle to be rotated in small amounts.
3. **Spindle Speed Knob:** When turned increases or decreases the spindle speed
4. **Coolant Switch:** Switches the coolant On or OFF
5. **Emergency Stop Button:** When pressed disconnects power to the control panel and stops the machine. To reset the stop button the top of the stop button must be twisted to allow the button to pop up.



Fig. 5.1

### HEADSTOCK SPEED CONTROLS (Fig. 5.2)

6. **High / Low Lever:** Switches between high and low speed in the gearbox.
7. **Digital Display:** Shows the speed of the spindle in R.P.M.
8. **Leadscrew Direction Lever:** Changes the direction of the leadscrew and feed shaft



Fig. 5.2

<b>! WARNING</b>	
<b>SAFETY FIRST</b>	<p><i>The safety instructions given in this manual can not be complete.</i></p> <p><i>The environment in every shop is different.</i></p> <p><i>Always consider your safety first as it applies to your individual working conditions.</i></p>
<b>SAFETY FIRST</b>	

SADDLE (Fig. 5.3)

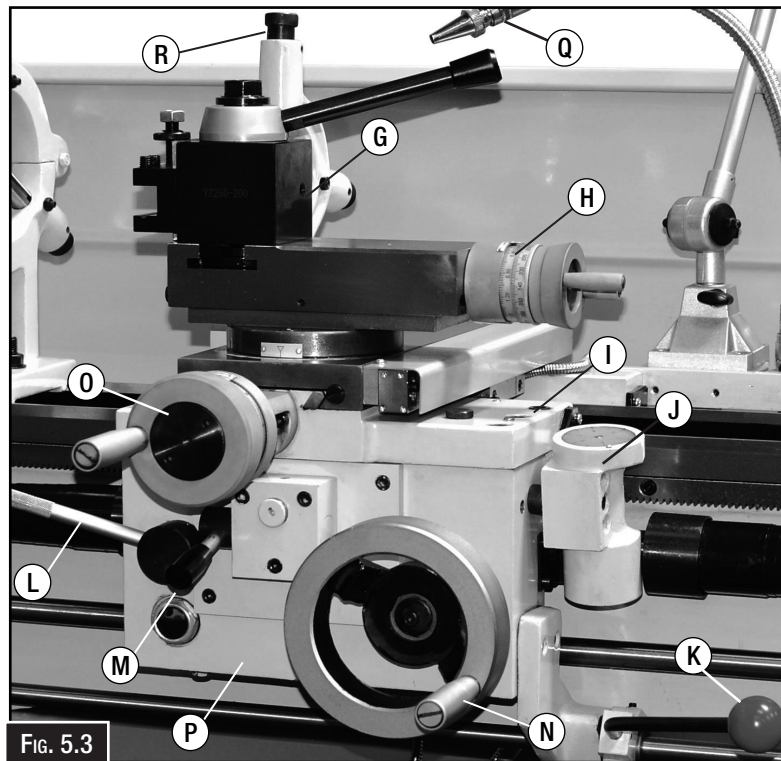

- G. **Quick Change Tool Post:** Allows the operator to load and unload tools.
- H. **Compound Rest Hand wheel:** Moves the tool toward and away from the workpiece at the pre-set angle of the compound rest.
- I. **Carriage Lock:** Secures the carriage in place for greater rigidity when it should not move.
- J. **Thread Dial:** Indicates when to engage the half nut during threading operations.
- K. **Spindle Lever:** Starts, stops and reverses direction of spindle rotation.
- L. **Half Nut Lever:** Engages/disengages the half nut for threading operations.
- M. **Feed Selection Lever:** Selects the carriage or cross slide for power feed.
- N. **Carriage Hand wheel:** Moves the carriage along the bed.
- O. **Cross Slide Hand wheel:** Moves the cross slide toward and away from the workpiece.
- P. **Apron:** Houses the carriage gearing.
- Q. **Coolant Hose:** Flexible coolant hose, that travels with the saddle.
- R. **Traveling Steady:** Travels with the saddle and is used to support thin materials and sits opposite the tool.

### Spindle ON/OFF Lever (Fig. 5.4)

Starts and stops the spindle in forward and reverse.

- Moving the lever upward from the central OFF position spins the chuck forward (the top of the chuck moves toward the machinist).
- Moving the lever downward from the central OFF position spins the chuck in reverse (the top of the chuck moves away from the machinist).

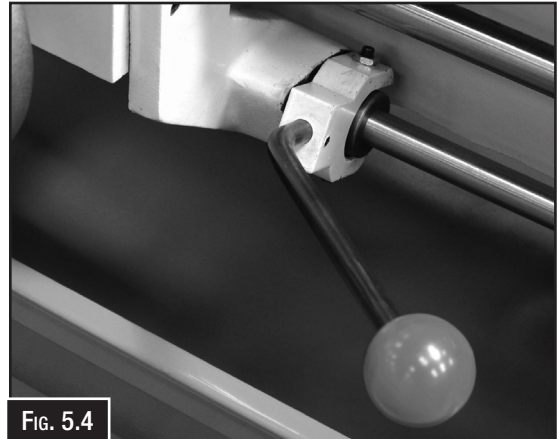

FIG. 5.4

### Foot Brake (Fig. 5.5)

This lathe is equipped with a foot brake to quickly stop the spindle. Pushing the foot brake while the spindle is ON cuts power to the motor and stops the spindle. Once stopped, the spindle ON/OFF lever **MUST** be returned to the neutral position before the spindle can be restarted.

**WARNING!**

**USING THE FOOT BRAKE TO STOP THE LATHE REDUCES RISK OF AN ENTANGLEMENT INJURY FROM ALLOWING THE LATHE TO COAST TO A STOP. USE THE FOOT BRAKE TO STOP THE LATHE WHENEVER POSSIBLE.**

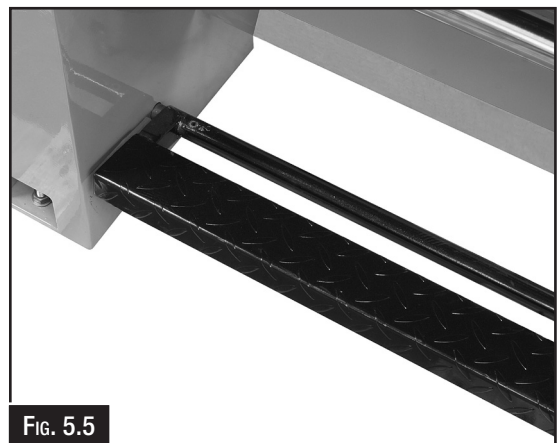

FIG. 5.5

### Slide Out Swarf Tray (Fig. 5.6)

The machine is fitted with a Slide out front swarf tray designed for easy cleaning.

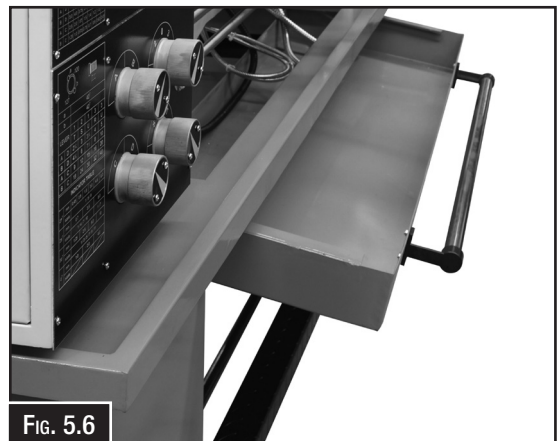

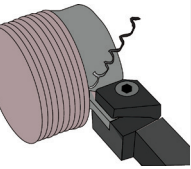

FIG. 5.6

 <b>WARNING</b>	
	<b><i>Always use leather gloves when handling swarf. Cuttings are sharp and can cause deep cuts and other injuries.</i></b>

**TAILSTOCK (Fig. 5.7)**

The tailstock has many functions. The main use is for holding drill chucks and centres.

The barrel has been etched with graduations in millimetres and inches and has a Morse taper #3 bore. The tailstock also can be offset to cut tapers.

- A. **Top Lock Lever** - This lever locks the tailstock barrel in place.
- B. **Side Lock Lever** - This lever locks the tailstock in place on the lathe bed.
- C. **Tailstock Hand-wheel** - Turning the hand-wheel advances or retracts the barrel in the tailstock.  
The graduated dial on the hand wheel is adjustable.
- D. **Tailstock Adjustment** - Two grub screws, (one either side) control the adjustment of the tailstock when taper turning is required.

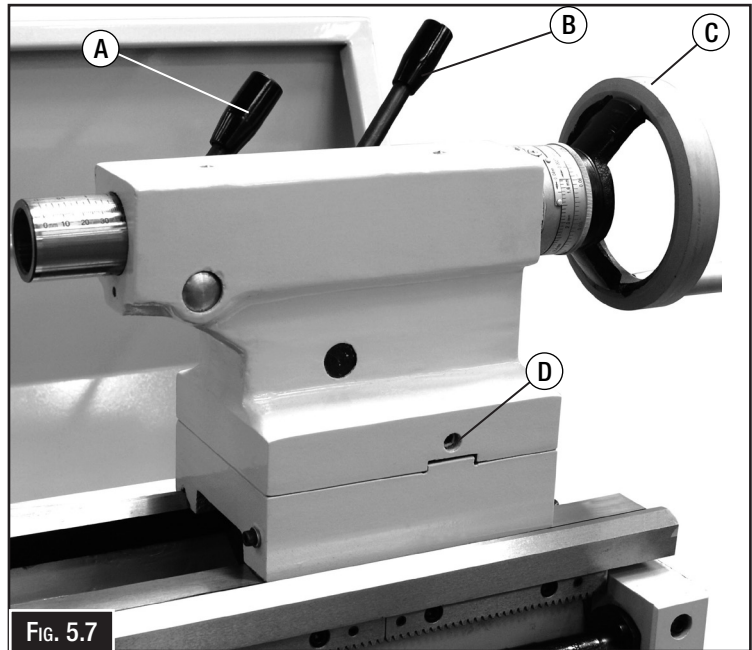

**STEADIES (Fig. 5.8)**

- E. **Knurled Screws** - Moves the fingers in or out to allow for adjustment.
- F. **Lock Nut** - When unlocked allows the fixed steady to be split to allow the steady to be placed around the work.

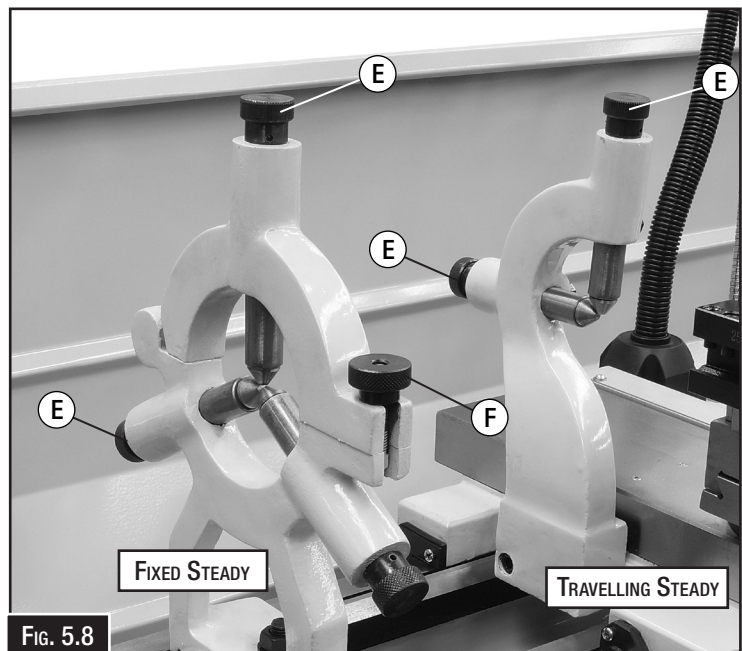

## 5.2 CHUCK & FACEPLATE MOUNTING

This lathe is equipped with a D1- 5 Camlock spindle nose. This type of spindle uses cams that are adjusted with a chuck key to securely mount a chuck or faceplate with repeatable precision and ease.

Because chucks are heavy and often awkward to hold, some kind of lifting, support, or protective device should be used during installation or removal. (Fig. 5.9)

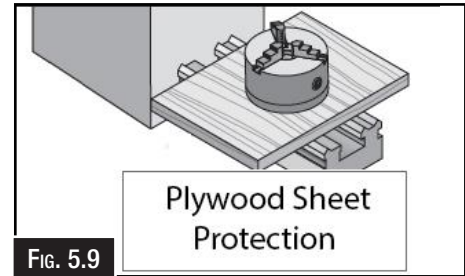

FIG. 5.9

To ensure that the work is accurate, it is extremely important to make sure the spindle nose and chuck mating surfaces and tapers are clean. Even a small amount of lint or dirt can affect the accuracy.

The chuck is properly installed when all camlocks are tight, the spindle and chuck tapers firmly lock together, and the back of the chuck is firmly seated against the face of the spindle all the way and without any gaps.

### Mounting The Chuck

Clean and lightly oil the camlock studs, then thoroughly clean the mating surfaces of the spindle and chuck.

Install the chuck by inserting the camlock studs straight into the spindle cam holes.

**NOTE: Avoid inserting the studs in from an angle or rotating the spindle. This can damage the studs or the cam holes. (Fig. 5.10)**

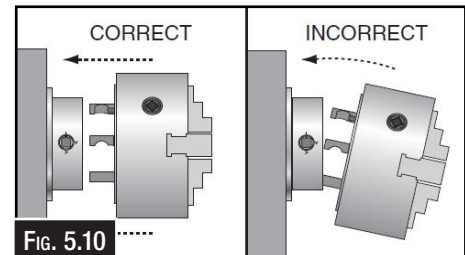

FIG. 5.10

When the chuck is fully seated and all the camlocks are tight, check that the cam line is between the two “V” marks on the spindle nose, as shown in Fig. 5.11.

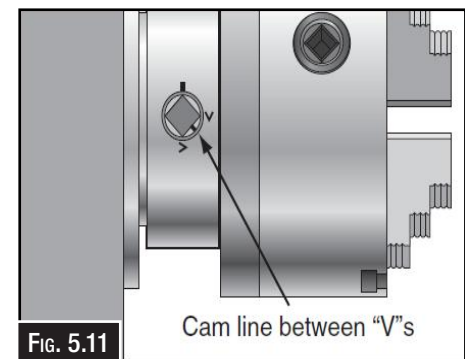

FIG. 5.11

If the cam line is not between the “V” marks when the camlock is tight, the stud may be installed at the incorrect height.

First check that the line on the cam is flush with the surface of the chuck. If it is not then adjust the stud height as shown in Fig. 5.12.

Make sure to re-install the stud cap screw afterward.

If adjusting the stud height does not correct the problem, try swapping stud positions on the chuck.

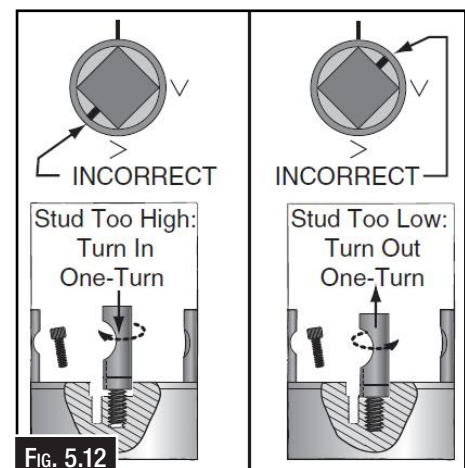
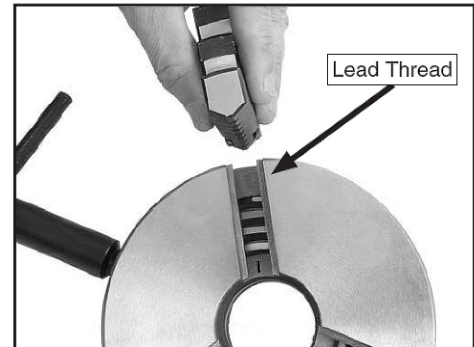
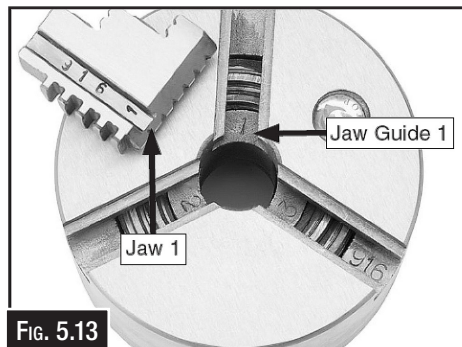

FIG. 5.12

### Changing Jaws on 3 Jaw Chuck (Fig. 5.13)

Changing jaws on a lathe chuck is a task that requires some care and attention to ensure it is done safely and correctly. Here are general steps that can guide you through the process:

1. Before you start, make sure the lathe is turned off and unplugged. Wear appropriate personal protective equipment such as gloves and safety glasses.
2. Ensure you have the correct replacement jaws that are compatible with your lathe chuck.
3. Make sure that the chuck and the replacement jaws have been thoroughly cleaned.
4. Insert the chuck key into a scroll keyway and rotate it until the jaws are released from the chuck body.
5. Examine the side of the jaws-each is stamped with a number 1 through to 3.
6. Examine the jaw guides of the chuck. Each is stamped with a corresponding number.
7. Slide the #1 jaw into the #1 jaw guide and hold it firmly against the scroll gear threads, then rotate the chuck key clockwise approximately one turn until the lead thread engages with the jaw. (Fig. 5.13) **NOTE: TUG ON THE JAW TO MAKE SURE IT IS ENGAGED WITH THE SCROLL GEAR THREAD.**
8. Repeat Steps 3-4 for jaws #2 and #3 in sequence.
9. Rotate the chuck key clockwise to bring the jaws together in the center of the chuck. If installed correctly, the jaws will converge evenly at the center of the chuck. If the jaws do not come together evenly, remove them, make sure the numbers of the jaws and the jaw guides match, then properly re-install them.



### Faceplate Or 4 Jaw Chuck (Fig. 5.14)

This section outlines basic operation safety related to using the faceplate included with your lathe. Use knowledge of safety and common sense when applying the steps on how to use this faceplate.

The faceplate is cast-iron and has multiple slots for T-bolts that hold clamping hardware. If you suspect that any of the chuck or jaw combinations may not hold a workpiece safely, remove the chuck and install the faceplate as outlined for special clamping options.

However, just as with the 4-Jaw chuck, not all work pieces can be safely held. Holding a workpiece off center or holding an irregular shaped workpiece will cause the entire assembly to rotate out of balance.

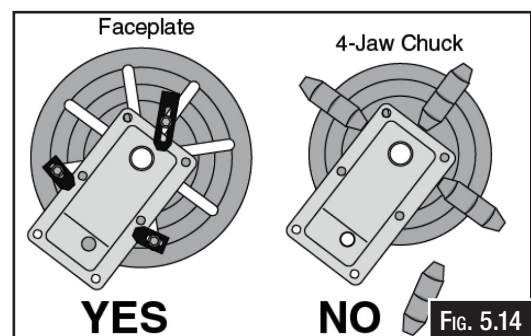

If spun any speed too high, the workpiece can eject hitting the lathe operator or bystanders causing a severe or fatal injury. Fig. 5.14 shows an example of a workpiece being improperly held with the 4-jaw chuck. One jaw of the chuck interfered with the workpiece edge, and removing the jaw creates an extreme workpiece ejection hazard. The workpiece holding solution shown in Fig. 5.14 is to use the faceplate with a minimum of three clamps that are spaced as equally apart as possible for full support.

### 5.3 SETTING THE CUTTING TOOL ON THE CENTERLINE

The tip of the cutting tool should be set up so that it is in line with the centreline of the spindle, as illustrated in Fig. 5.15.

The cutting tool can be raised by placing steel shims underneath it. The shims should be as long and as wide as the cutting tool to properly support it.

There are a number of ways to check that the cutting tool is on the centre line of the spindle.

Below are two common methods:

1. Move the tailstock center over the cross slide and use a fine ruler to measure the distance from the surface of the cross slide to the tip of the center. Adjust the cutting tool height so it is the same distance above the cross slide as the tailstock center.
2. Align the tip of the cutting tool with a tailstock center, as described in the following procedure. (Fig. 5.16)
  - a. Mount the cutting tool and secure the post so the tool faces the tailstock.
  - b. Install a center in the tailstock, and position the tip near the cutting tool.
  - c. Lock the tailstock and quill in place.
  - d. Adjust the height of the cutting tool tip to meet the center tip, as shown. (Fig. 5.16)

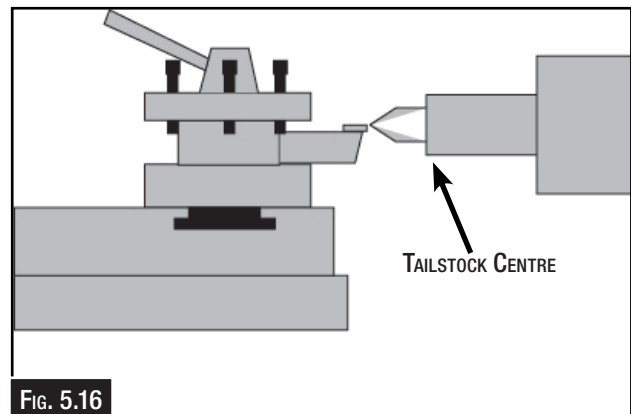
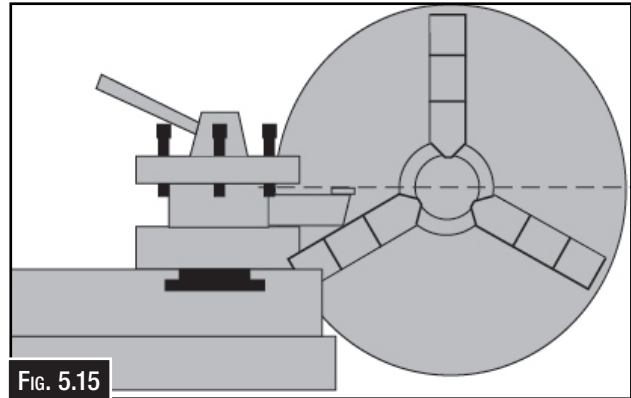

## WARNING!

*The machine is the sole responsibility of the owner for its safe use. This responsibility includes but is not limited to proper installation in a safe environment, personnel training, proper inspection and maintenance, manual availability and comprehension. The manufacturer will not be held liable for injury or property damage from negligence, improper training, machine modifications or misuse.*

## 5.4 SPINDLE SPEEDS

Using the correct spindle speed is important for getting safe and satisfactory results, as well as maximizing tool life.

To set the spindle speed for your operation, you will need to:

- 1) Determine the best spindle speed for the cutting task,
- 2) Configure the lathe controls to produce the required spindle speed.

### Determining Spindle Speed

Many variables affect the optimum spindle speed to use for any given operation, but the two most important are the recommended cutting speed for the workpiece material and the diameter of the workpiece, as noted in the formula shown below.

$$\frac{\text{RECOMMENDED CUTTING SPEED (MTRS/MIN)} \times 1000}{\text{DIAMETER IN MILLIMETERS} \times 3.14} = \text{RPM}$$

The Fitting & Machining handbook (L341) and some Internet sites, provide excellent recommendations for which cutting speeds to use when calculating the spindle speed. These sources also provide a wealth of additional information about the variables that affect cutting speed and they are a good educational resource.

#### Example:

1. Set the High/Low lever. (A in Fig. 5.17)  
Low 40 - 400 rpm. range  
High 220 - 1800rpm. range
2. Adjust the speed knob (B in Fig. 5.17) until the correct speed is selected and displayed in the digital Display (C in Fig. 5.18)

**Note:** If the spindle High or Low speed levers do not easily adjust into position, rotate the spindle by hand while you apply pressure to the lever. When the gears align, the lever will easily move into place. If you have trouble you can use the spindle key or a chuck key to get additional leverage, just be sure to remove the key when you are done.



Fig. 5.17

<b>WARNING</b>	
	<b>To avoid damaging gears, ALWAYS make sure the spindle is completely stopped BEFORE moving the High/Low lever.</b>

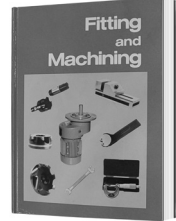

Fig. 5.18

## 5.5 THREADING

The machine is designed to cut most metric and inch threads. The following sections will describe how to use the threading controls to set up the lathe for a threading operation. If you are unfamiliar with the process of cutting threads on a lathe, it is strongly recommend that you read a trade manual such as HAFCO L341, or seek formal training before attempting any threading projects. Consult the thread charts for the correct lever settings.

ORDER CODE L341



		Metric								Imperial						
		leadscrew threads: 4mm								leadscrew threads: 4mm						
		120								127						
		a								a						
		b								b						
LEVER		4	1	4	2	3	1	3	3	LEVER		1	2	1	3	3
		T	T	R	S	S	U	R	U			T	S	U	R	U
A	D	10	8.0	7.5	6.0	5.6	4.8	4.5	3.6	A	D	2 1/4	3	3 3/4	4	5
B	D	5.0	4.0	3.75	3.0	2.8	2.4	2.25	1.8	B	D	4 1/2	6	7 1/2	8	10
A	C	2.5	2.0	1.875	1.5	1.4	1.2	1.125	0.9	A	C	9	12	15	16	20
B	C	1.25	1.0	0.9375	0.75	0.7	0.6	0.5625	0.45	B	C	18	24	30	32	40

FIG. 5.19

### Feed & Threading Gearbox

The setup procedure on this lathe is the same for metric & inch threads. These thread selections are indicated by a series of letters and numbers shown on the headstock threading charts. First, the change gear positions are checked and rearranged if indicated by the chart. Next, the quick change gearbox knobs and levers are moved to specific positions also indicated by the chart.

#### To set up for threading:

1. DISCONNECT LATHE FROM POWER!
2. Open the change gear door on the left hand side of the headstock to expose the change gears.
3. Review the threading chart for the required thread to be cut (Fig. 5.19). The chart indicates that to cut a 0.50 metric thread, the change gears and feed dials must be in the following positions.
4. Turn the first knob of the quick change gearbox to "B" position, turn the second knob to "T" position, turn the third knob to "D" position and turn the fourth knob to "I" position. (Fig. 5.20). Leaving 0.08mm–0.15mm backlash between gear teeth, arranges the 30 teeth change gear to 120 teeth and 120 teeth to 40 tooth change gear.
5. Rotate the spindle by hand to verify no binding exists, and close the gear door.

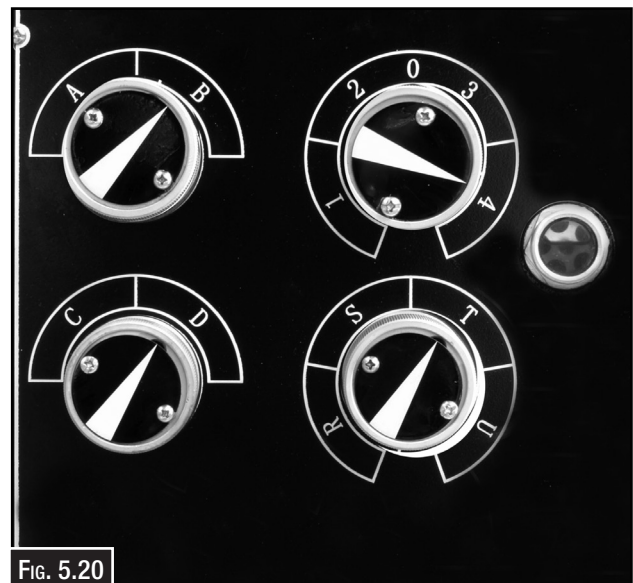
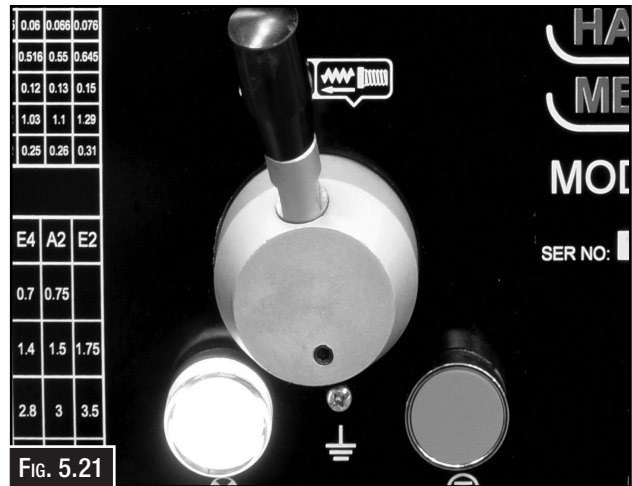

FIG. 5.20

### Leadscrew Direction

Selects the direction for lead screw and the power feed. (Fig. 5.21). When lever is positioned to the right side, the carriage will move to the left along the bed, or the cross feed will travel toward the front of the lathe.



### Thread Chasing Dial

The numbers on the thread dial are used with the thread dial chart (Fig. 5.22) to show when to engage the half nut during metric threading. (Fig. 5.22)

When cutting metric threads and the pass has been completed, the thread dial (Fig. 5.22) allows the operator to disengage the carriage from the leadscrew, and quickly return the carriage for the next pass. Based on the thread pitch being cut, and what is indicated on the Indicator Table, the dial indicates where the operator must re-clamp the half nut in order to resume the same thread to avoid cross-cutting threads.

When cutting some inch or other types of threads, the half nut may have to be clamped to the leadscrew until the threads are complete, otherwise the path of the same thread will be lost. In this case carriage returns for are made by backing the tool point out of the thread, and reversing spindle rotation with the spindle ON/OFF lever.

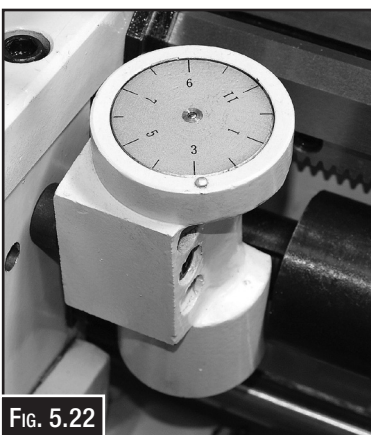

INDICATOR TABLE					
	mm			mm	
<b>T</b>	<b>mm</b>		<b>T</b>	<b>mm</b>	
<b>0</b>	<b>1.0</b>		<b>28</b>	<b>0.7</b>	<b>1/4/7/10</b>
	<b>2.0</b>			<b>0.875</b>	<b>1/4/7/10</b>
	<b>4.0</b>			<b>1.75</b>	<b>1/4/7/10</b>
<b>27</b>	<b>0.45</b>	<b>1/5/9</b>		<b>3.5</b>	<b>1/4/7/10</b>
	<b>0.6</b>	<b>1/5/9</b>		<b>7</b>	<b>1/4/7/10</b>
	<b>1.5</b>	<b>1/5/9</b>	<b>8.0</b>	<b>1/7</b>	
	<b>3.0</b>	<b>1/5/9</b>	<b>30</b>	<b>1.25</b>	<b>1/3/5/7/9/11</b>
	<b>4.5</b>	<b>1/5/9</b>		<b>2.5</b>	<b>1/3/5/7/9/11</b>
<b>6.0</b>	<b>1/5/9</b>	<b>5.0</b>		<b>1/3/5/7/9/11</b>	
			<b>10</b>	<b>1/3/5/7/9/11</b>	

### Half Nut Lever

When the feed selection lever and carriage lock are disengaged, the half-nut lever can be moved downward from the disengaged upper position to clamp the half nut around the leadscrew for threading operations. (Fig. 5.23)

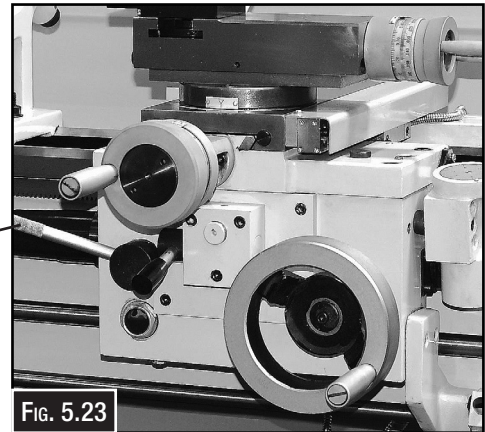
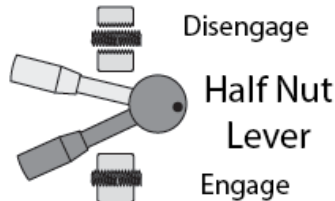

### Procedure for threading:

1. Set the speed to about one quarter of the speed used for turning.
2. Set the quick change gearbox for the required pitch in threads.
3. Set the compound rest at 29 degrees to the right for right hand threads.
4. Install a 60 degree threading tool bit for metric threads or a 55 degree tool for imperial threads and set the height to the lathe center point.

Align your threading tool against a freshly faced end or against the side of the chuck.

- Align your threading tool against a freshly faced end or against the side of the chuck. The little arrow-shaped alignment tools you see are a pain and are only good for gauging hand-ground tool bits.
- If you do a lot of threading on a manual lathe, invest in a tool that accepts inserts. The inserts are precisely ground and easily changed. One insert cuts dozens of thread pitches.
- I learned how to thread on the lathe using the compound infeed method. Contrary to popular belief, the compound set doesn't have to be at half the thread angle. By using what's called "modified-flank infeed" and changing this angle, you help alleviate threading problems in difficult-to-cut materials.

Order Code	Description	
<b>Q138</b>	<b>10-138 - Screw Thread Micrometers</b> 0-25mm Metric	
<b>Q139</b>	<b>10-139 - Screw Thread Micrometers</b> 25-50mm Metric	

## 5.6 CHANGE GEARS

The end gears are used to setup for power feed, inch, or metric threading operations. See (Fig. 5.24) to identify the upper gear, middle 120T/127T change gears, and the lower gear. Details on which gear to use are found on the headstock feed and threading charts.

### Change Gear Configuration

To configure the change gears:

1. Locate the chart on the headstock that has the thread or feed option that is required.
2. **DISCONNECT THE MACHINE FROM POWER!**
3. Remove the headstock end gear cover.
4. While holding the 120T/127T gears, loosen the arm by undoing the gear support hex nut and slowly let the gears pivot down and away from the upper top gear, as illustrated (Fig. 5.25)
5. Loosen the 120T/127T gear hex nut and slide the middle gear away from the bottom gear. The 120T/127T gears may need to be reversed. Undo the 120T/127T gear hex nut (Fig. 5.25) and reverse the gears.
6. Remove the cap screw and flat washer from the top gear, then slide the gear off the shaft. Slide the desired gear onto the top gear shaft and desired gear onto the bottom gear shaft making sure to align the keys and keyways. Position the flat, non-stepped face of the gears away from the headstock so they will mesh with either the 120T or 127T gear depending on which one is required.
7. Secure the top and bottom gears with the flat washers and cap screws that were removed earlier
8. Raise the gear support arm and mesh the top gear with the 120T/127T, then tighten the arm support hex locking nut and replace the change gear cover. (Fig. 5.26)

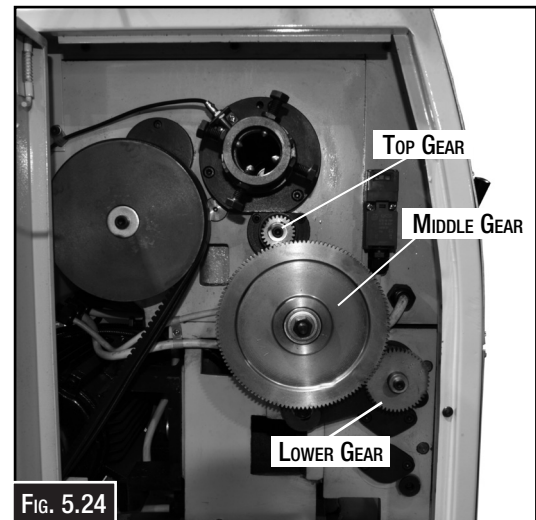

FIG. 5.24

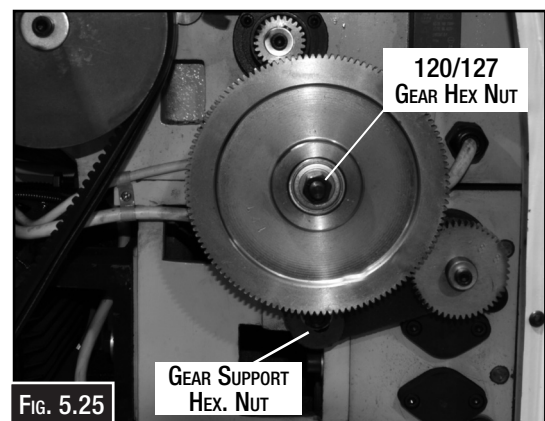

FIG. 5.25

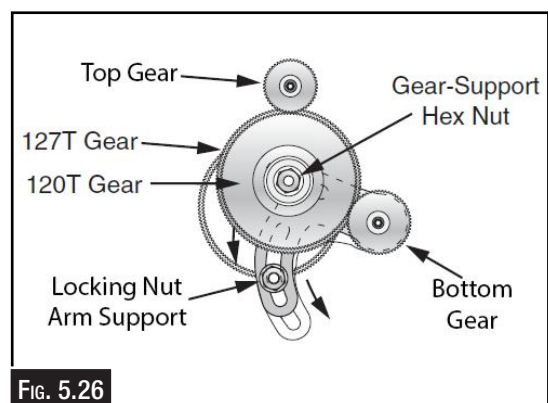

FIG. 5.26

## 5.7 SELECTING THE FEEDS

The AL-346V Metal Lathe can cut left or right while feeding or threading, and both ways for facing operations. This feed direction is controlled by the selection knob on the headstock (Fig. 5.27)

**NOTE: The feed direction knob should not be changed while the spindle is rotating.**

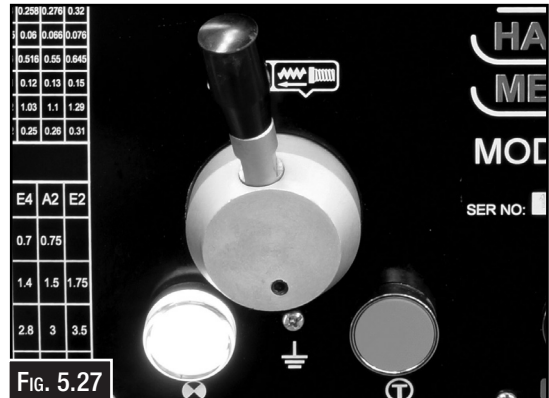

Fig. 5.27

### Selecting the Feed Rod

The feed rod can be selected by rotating the “top right hand dial to the “0” position. (Fig. 5.28). Use this position for all feeding operations. When the knob is the other positions, threading selections can be made.

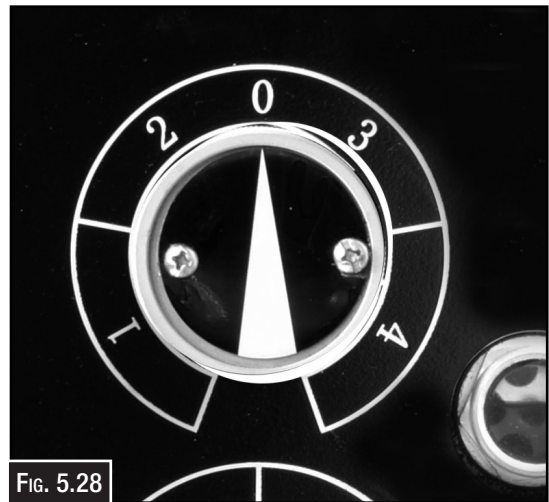

Fig. 5.28

**Feed Lever** - Longitudinal and cross slide powered feeds are controlled by the feed lever. The lever pivots through two stops which require moving the lever left and right as well as up and down.

Moving this lever upward activates the automatic longitudinal feed. Moving the lever down activates the cross slide for facing operations. (Fig. 5.29)

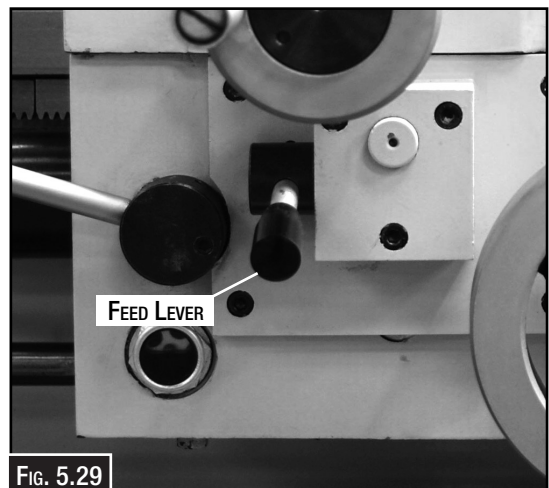
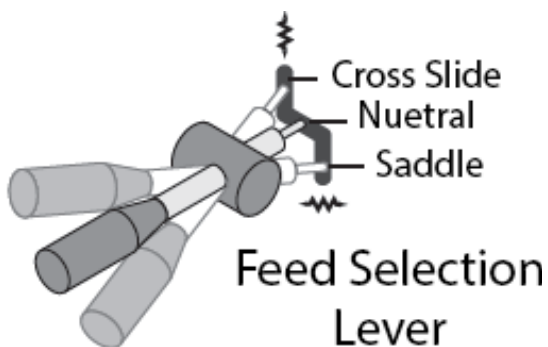
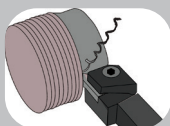

Fig. 5.29



### **WARNING!**

**STOP the machine before attempting to remove the swarf. Use leather gloves when handling swarf. Cuttings are sharp and can cause injury.**

## 5.8 QUICK CHANGE TOOLPOST

The included toolpost is a 250 series piston type quick-change model. The quick change lock lever allows for one or more tool holders to be quickly loaded and unloaded in two available dovetailed slots. By having extra tool holders and setting the tool height in advance, swapping between tooling is efficient for production sensitive schedules. When loosened, the mounting hex nut allows the entire toolpost to rotate 360° for angle adjustments.

### To load a tool holder:

1. Install the required cutting tool in the tool holder.
2. Move the quick-change lever (Fig. 5.30) to recess the lock piston and provide an unobstructed slot for the tool holder to slide down into.
3. Slide the tool holder into position, and tighten the quick-change lever.
4. Use the handwheels to bring the tool to the required position.
5. Double check that tool angle, height, and position are correct.
6. Make sure that all fasteners related to the tool, holder, and toolpost are tight.

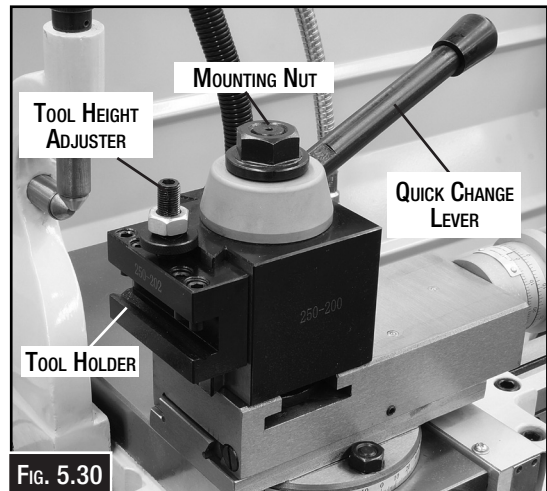

Fig. 5.30

## OPTIONAL TOOL HOLDERS

### Standard Holder for Quick Change Toolpost

ORDER CODE L291A  
Suits 16mm Tool.



### Parting Holder for Quick Change Toolpost

ORDER CODE L291B  
Optional Accessory  
1/2" Part Off Blade - High Speed Steel Bit (L0007)



### Knurling Holder for Quick Change Toolpost

ORDER CODE L291C  
Cross Knurls



### Standard Holder for Quick Change Toolpost

ORDER CODE L292D  
Suits 20mm Tool



### WARNING.

*Before operating any machine, take time to read and understand all safety signs and symbols. If not understood seek explanation from trade magazines or an experienced operator.*

## 5.9 ALIGNING TAILSTOCK TO SPINDLE CENTERLINE

By offsetting the tailstock, the dead center can hold a workpiece off centre from the spindle centerline so tapers and pipe threads can be cut. An offset scale (Fig. 5.31) with increments is located at the rear of the tailstock. However, to achieve exact taper angles, or to adjust the tailstock back into the spindle centerline, angle gauges and a test indicator must be used.

### To offset the tailstock:

1. Loosen the tailstock lock lever.
2. Using a hex wrench loosen one of the front or rear adjustment screws shown in Fig. 5.31.
  - To move the tailstock toward the rear of the lathe, loosen the rear adjustment screw and tighten the front screw.
  - To move the tailstock toward the front of the lathe, loosen the front adjustment screw and tighten the rear screw.
3. Apply the tailstock lock lever, and check the amount of the tailstock offset. Unlock and readjust as required for fine tuning.

### Aligning Tailstock

1. Center drill a 150mm long piece of bar stock on both ends. Set it aside for use in Step 4.
2. Make a dead center by turning a shoulder to make a shank. Flip the piece over in the chuck and turn a 60° point (Fig. 5.32). As long as it remains in the chuck, the point of your center will be accurate to the spindle axis.
3. Place the live center in your tailstock.
4. Attach a lathe dog to the chuck bar stock from step 1, and mount between the centers. (Fig. 5.33)
5. Turn approximately 0.25mm off the diameter.
6. Mount a dial indicator so that the plunger is on the tailstock quill. (Fig. 5.33)
7. Measure the stock with a micrometer. If the stock is wider at the tailstock end, the tailstock needs to be moved toward the front of the lathe half the amount of the taper. If the stock is thinner, at the tailstock end, the tailstock needs to be moved toward the rear of the lathe by half the amount of the taper. (Fig. 5.33)

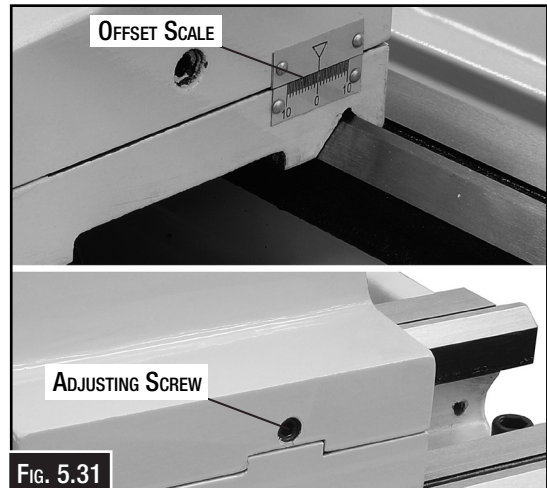

Fig. 5.31

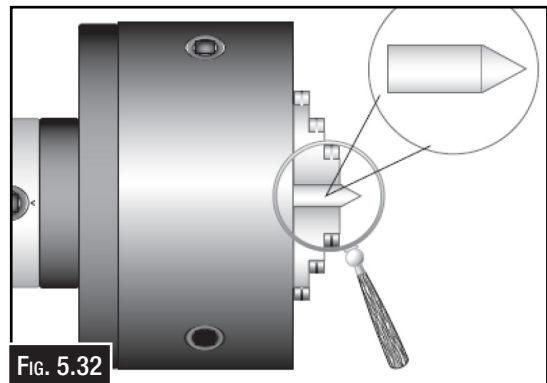

Fig. 5.32

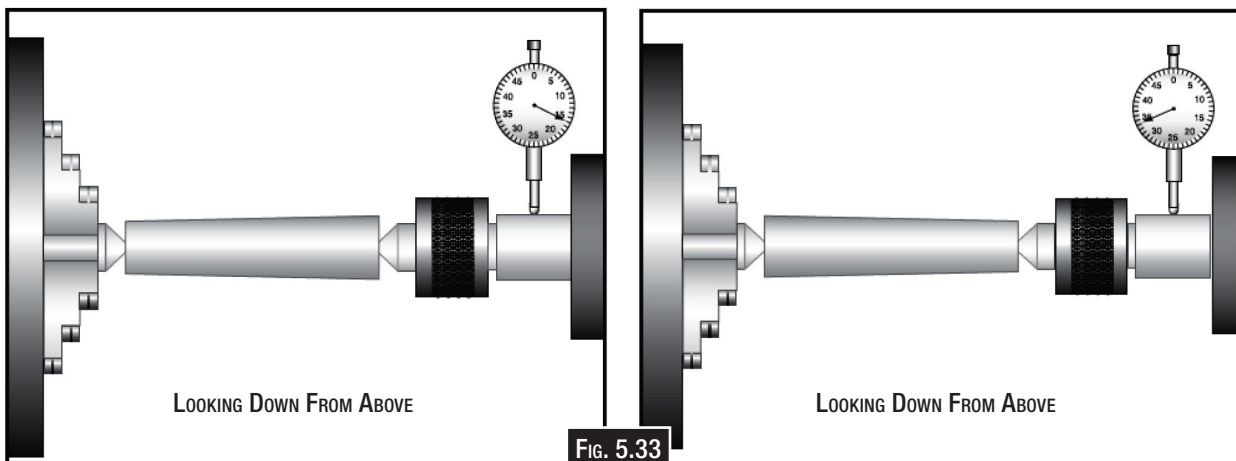

Fig. 5.33

## 5.10 REMOVING AND REPLACING THE BED GAP

This AL-346V Lathe bed is equipped with a removable gap that allows for the turning of large diameter workpieces. The gap was seated, pre-loaded, and then ground for precise mating and alignment at the factory.

Removing the gap can cause the lathe insert to slightly spring out of shape. When re-installed, there is no guarantee that original alignment and flush mating will be the same. For this reason, removing the gap is considered a permanent alteration to the lathe, even if it is later re-installed.

### To Remove The Gap

1. Disconnect lathe from power!
2. Loosen the preload set screw a few turns until it no longer contacts the headstock. (Fig. 5.34)
3. Tighten the dowel-pin jack nut to draw the pins from the gap.
4. Remove the four cap screws that secure the gap to the bed.
5. Tap the outside of the gap piece with a dead blow hammer to loosen it, and, with the help of another person, remove the gap piece.

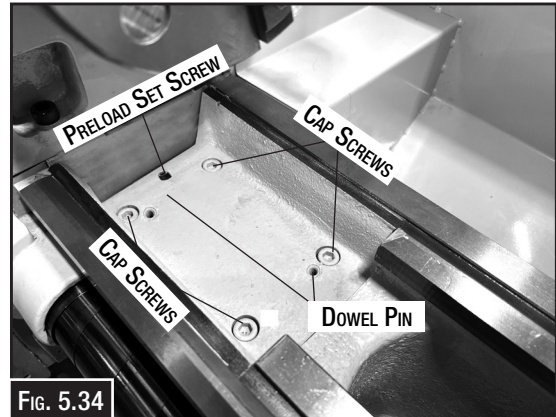

### To Replace The Gap

1. Disconnect lathe from power!
2. Clean the mating surfaces.
3. Place the gap in the bed. Tap the dowel-pins in to align the gap.
4. Place the four cap screws that secure the gap to the bed.
5. Tighten the 4 screws and the preload screw.



## 5.11 SPINDLE SPIDER

The lathe is equipped with an outboard spindle steady rest also known as a spider. (Fig. 5.35)

The spindle spider is designed for supporting long shaft work operations. It is a support for any long workpiece that extends through the rear side of the spindle.

Each tip of the spider screws have brass wear pads that hold the workpiece without placing indents in the finish surface.

When the spider screws are used, always tighten the lock nuts on each screw, to ensure that the screws cannot move. There is a possibility that a loose screw could cause a collision with the change gears cover.

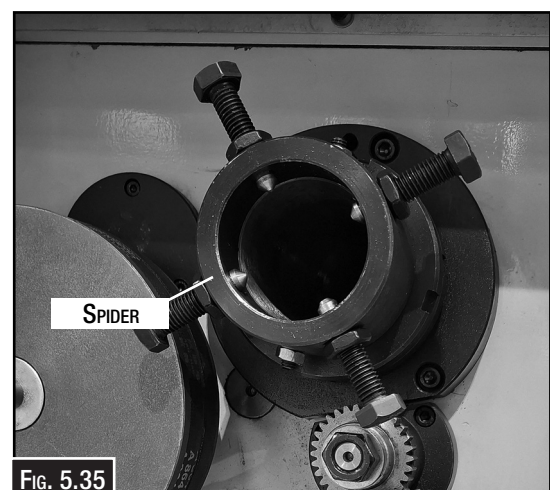

## 5.12 COOLANT SYSTEM

The cutting fluid system delivers cutting fluid via a flexible distribution hose and nozzle. The cutting fluid pump turns ON and OFF with a switch located on the control panel. Fluid flow is controlled by a manual flow control valve. (Fig. 5.35)

**NOTE! RUNNING THE PUMP WITHOUT ADEQUATE CUTTING FLUID IN THE RESERVOIR MAY PERMANENTLY DAMAGE IT. THIS TYPE OF DAMAGE IS NOT COVERED BY THE WARRANTY. ALWAYS USE HIGH QUALITY CUTTING FLUID AND FOLLOW THE MANUFACTURER'S INSTRUCTIONS FOR DILUTING. FREQUENTLY CHECK THE CUTTING FLUID CONDITION AND CHANGE IT PROMPTLY WHEN IT BECOMES OVERLY DIRTY OR RANCID.**

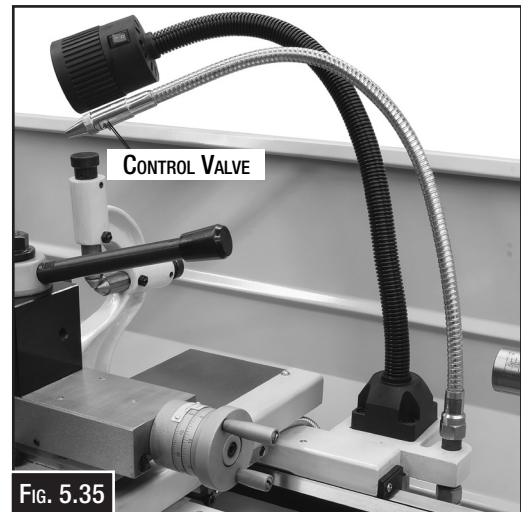

Fig. 5.35

**WARNING! BIOLOGICAL AND POISON HAZARD! USE THE CORRECT PERSONAL PROTECTION EQUIPMENT WHEN HANDLING CUTTING FLUID AND BY FLUID MANUFACTURER REQUIREMENTS TO PROPERLY DISPOSE OF CUTTING FLUID.**

### Checking cutting fluid system

When checking the cutting fluid system, the goal is to make sure there is enough cutting fluid, the chip level in the first chamber is not too high, and the cutting fluid has not become rancid or contaminated.

#### To Check The Cutting Fluid System:

1. Disconnect lathe from power!
2. At the tailstock end of the lathe, remove the pump access cover.
3. Inspect the level of cutting fluid inside the tank. The cutting fluid should be approximately 25mm below the top of the tank.
4. Using a wooden stick, check the level of the metal chips in the first chamber (Fig. 5.36). If the chips are 3/4 the height of the baffle, then remove the chips.
5. Inspect the cutting fluid quality as outlined by the fluid manufacturer and replace as recommended.

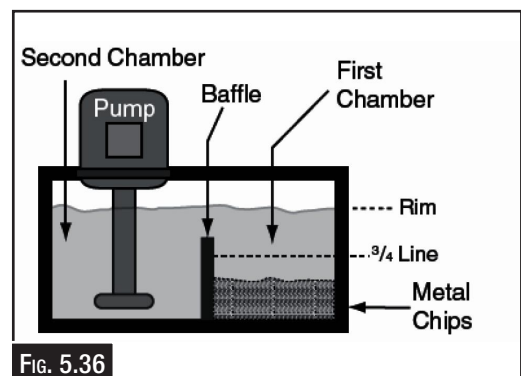

Fig. 5.36

### Cleaning Cutting Fluid System

1. Place the drain hose on the end of the coolant nozzle, and pump the used cutting fluid into the drain bucket. As soon as pumping is complete turn the pump OFF immediately.
2. Disconnect lathe from power!
3. Lift the tank assembly from the lathe stand.
4. Remove all metal shavings, any remaining cutting fluid, and clean out the tank.
5. Clean the intake screen on the pump.
6. Reinstall the cutting fluid tank into the lathe stand.
7. Mix the cutting fluid to the manufacturer's required specification, and fill the cutting fluid tank
8. Reinstall the pump access cover.

## 6. MAINTENANCE

### 6.1 LUBRICATION



#### **WARNING**

*Before maintaining or cleaning the machine, turn off the circuit breaker, or disconnect the machine from the power supply.*

*Post a sign to inform other workers that the machine is under maintenance.*

For optimum performance from the machine, it is important that the machine is well lubricated and maintained. Follow the maintenance schedule listed in the following section and refer to any specific instructions given.

*Use the information in the charts below as a daily guide for lubrication tasks*

Assembly	Part	Method	Lubricant	Interval
Headstock	Spindle Gears and Bearings	Oil Bath	Machine Oil	6 Months
Feed Box	Gears and Bearings	Oil Bath	Machine Oil	Check site glass daily and fill as required
Carriage	Gears and Bearings	Oil Bath	Machine Oil	Check site glass daily and fill as required
End Gears	Change gears and quadrant	Oil Can	Machine Oil and Grease	Once per shift
Carriage Slide	Bedway slides	Oil Can	Machine Oil	Once per shift
Cross Slide	Slides and Screws	Oil Can	Machine Oil	Once per shift
Tailstock	Quill and Screw	Oil Can	Machine Oil	Once per shift
Feed Screw	Screws and Bearings	Oil Can	Machine Oil	Once per shift
Lead Screw	Screw	Oil Can	Machine Oil	Annually

## 6.2 LUBRICATION POINTS

### Headstock

The headstock reservoir has the proper amount of oil when the oil level in the sight glass is approximately halfway. (Fig. 6.1) The oil sight glass is located below the chuck, The oil should be changed every six months by firstly draining the oil by removing the drain plug (Fig. 6.2) then filling by the oil filler plug (Fig. 6.3)

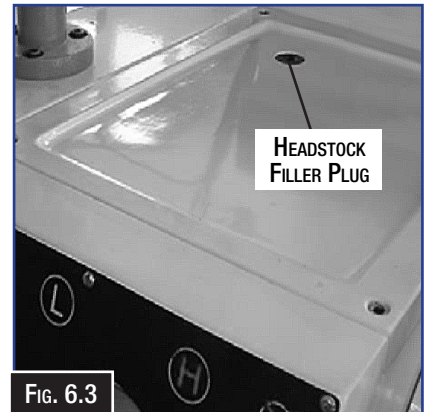
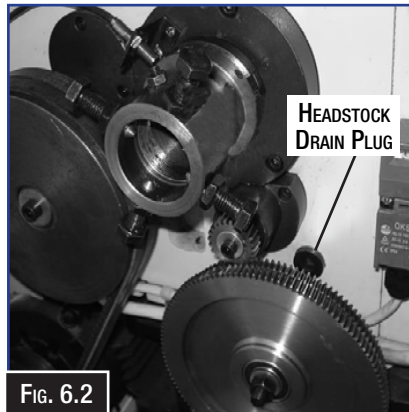
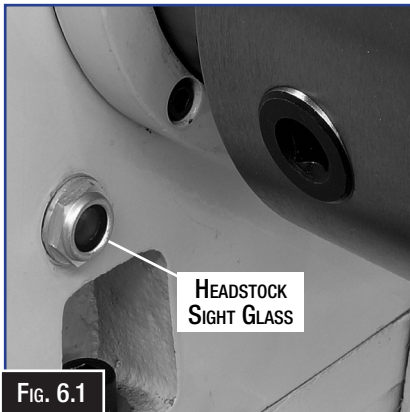

### APRON

The apron oil sight glass is on the front of the apron, as shown in Fig. 6.4. Maintain the oil volume so that the level is approximately halfway in the sight glass.

### Changing Oil & Flushing Reservoir

Small metal particles may accumulate at the bottom of the reservoir with normal use. Therefore, to keep the reservoir clean, drain and flush it at least once a year. Place a catch pan under the apron drain plug (Fig. 6.4), remove the fill plug, then use a 6mm hex wrench to remove the drain plug and empty the reservoir.

Flush the reservoir by pouring a small amount of clean oil into the fill hole and allowing it to drain out the bottom.

Replace the drain plug, add oil as required, then re-install the fill plug.

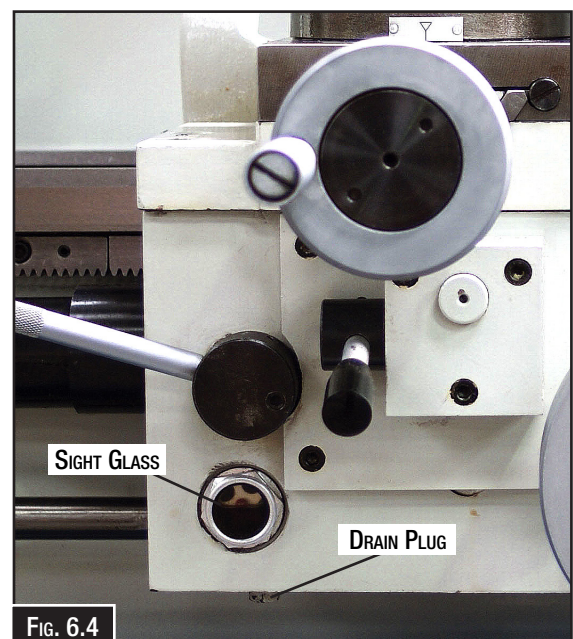

## Gearbox

The quick change gearbox has an oil reservoir that is equipped with a sight glass for the quick checking of the oil level. Before and after every use, make sure that the oil level is correct. Fig. 6.5 & Fig. 6.6 show the gearbox locations of the sight glasses and the fill/drain plugs.

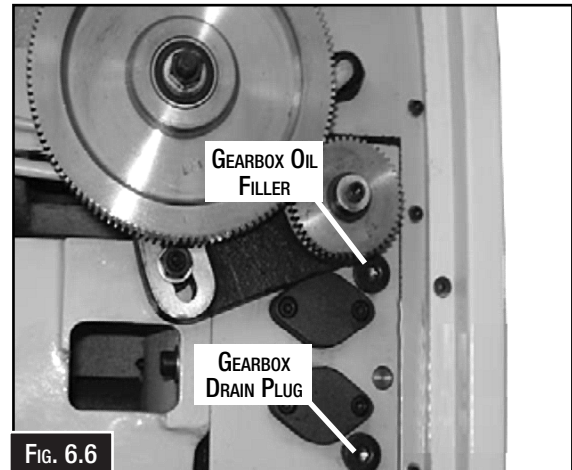
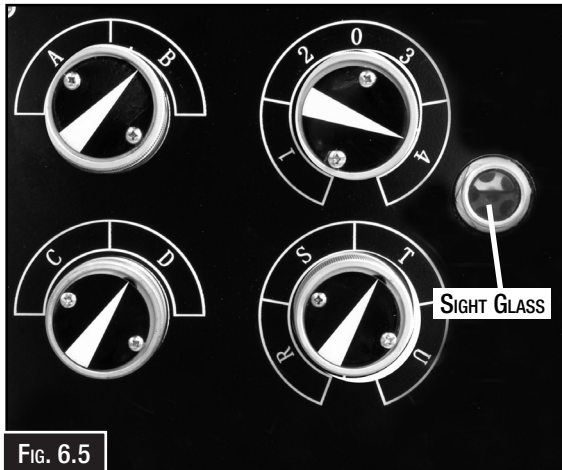

### To add oil to the reservoir:

1. Clean the area around the fill plug to prevent debris from falling in the reservoir when adding oil.
2. Remove the fill plug.
3. Slowly add oil until the oil level is centered in the sight glass.
4. Replace fill plug.

### Changing oil

The oil in the reservoirs must be changed after the first three months of operation, then twice a year after that. If the lathe is under heavy use, more frequent oil changes will be required to keep the gearboxes clean and ensure long machine life. Some lathe owners believe that by using full synthetic oils in the gearboxes is a way to extend oil change intervals. We do not recommend this practice. While synthetic oils are superior this lathe does not use a filter to remove contaminants that are generated during normal use, such as when shifting gears. Changing the oils on a frequent basis to flush out moisture and contaminants is still the best option to ensure long gearbox life.



### **CAUTION!**

*Before attempting this feature, disconnect the machine from the power supply to avoid injury to the operator from accidental startup or damage to the machine*

## Longitudinal Leadscrew

Undo the end of the lead screw cover and slide it to the end of the shaft. Before lubricating the lead screw (Fig. 6.7) it should be cleaned with mineral spirits. The use of a stiff brush will help clean out the threads. Move the carriage out of the way, so you can clean the entire length of the lead screw. Apply a thin coat of oil along the length of the lead screw. Use a stiff brush to make sure the oil is applied evenly and down into the threads. Replace the lead screw cover.

Lead Screw & Feed Shaft Bearings (Fig. 6.8). The feed and leads screw bearings are lubricated through ball oilers at the end of the bed. Lubricate with machine oil and check each shift.

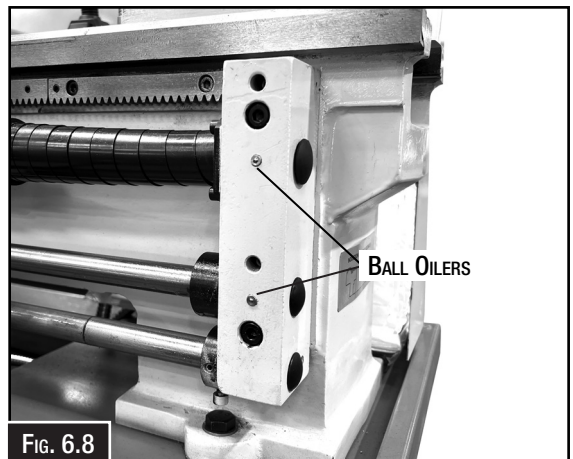
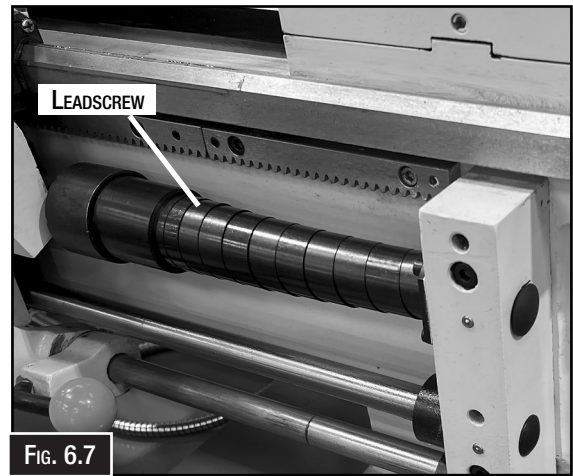

## Ball Oilers (Fig. 6.9)

Proper lubrication of ball oilers is done with a pump-type oil can that has a plastic or rubberized cone tip, usually supplied with the accessories.

Lubricate the ball oilers before and after machine use, and more frequently under heavy use. When lubricating ball oilers, first clean the outside surface to remove any dust or grime. Push the tip of the oil can nozzle against the ball oiler to create a hydraulic seal, then pump the oil can once or twice. It is important not to press the ball oiler too hard with nozzle of the oil can as it may cause the ball to jam in the open position, allowing dirt to enter. If you see sludge and dirt coming out of the lubrication area, keep pumping the oil can until the oil runs clear. When finished, wipe away any excess oil.

Oilers can be found below

- Cross-slide leadscrew & slides
- Compound-rest leadscrew & slides
- Saddle slides
- Carriage handwheel
- Feed selection lever gearing
- Tailstock ball oilers
- Leadscrew end bearing
- Feed rod end bearing

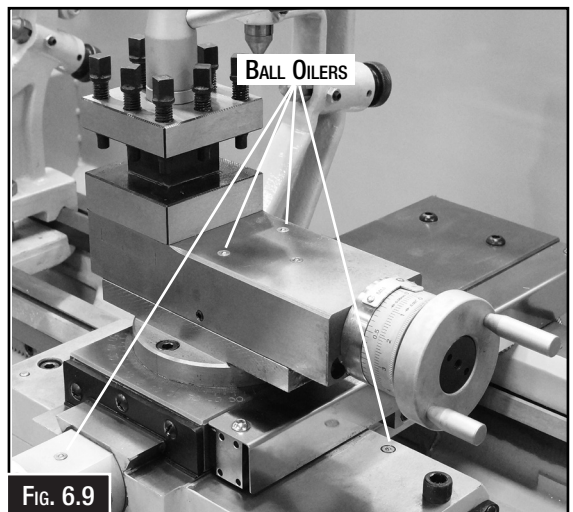

## 6.3 TROUBLESHOOTING

Review the troubleshooting and procedures in this section if a problem develops with your machine. If you need replacement parts then follow the procedure in the beginning of the spare parts section or if additional help with a procedure is required, then contact your distributor.

**Note: Make sure you have the model of the machine, serial number, and manufacture date before calling.**

Symptoms	Possible Cause	Possible Solution
Motor will not start	<ol style="list-style-type: none"> <li>1. Stop button not reset.</li> <li>2. Main power panel switch is OFF</li> <li>3. Circuit breaker or fuse has tripped.</li> <li>4. No voltage or open connection</li> <li>5. Faulty capacitor.</li> <li>6. Spindle ON/OFF switch is at fault</li> <li>7. Power switch or magnetic contactors faulty</li> <li>8. Faulty Motor</li> </ol>	<ol style="list-style-type: none"> <li>1. Reset the stop button.</li> <li>2. Turn the main power panel switch ON</li> <li>3. Seek an electrician to trouble shoot and repair.</li> <li>4. Test circuit and connections as required.</li> <li>5. Replace capacitor.</li> <li>6. Replace switch.</li> <li>7. Replace power switch or magnetic contactor.</li> <li>8. Replace motor.</li> </ol>
Fuses or circuit breakers trip open	<ol style="list-style-type: none"> <li>1. Short circuit in power lead or plug</li> <li>2. Short circuit in motor or loose connections</li> <li>3. Incorrect fuse or circuit breakers in power supply</li> </ol>	<ol style="list-style-type: none"> <li>1. Inspect cord or plug for damage, repair or replace.</li> <li>2. Inspect all connections on motor. Repair as required.</li> <li>3. Install correct fuses or circuit breakers.</li> </ol>
Machine is loud, belt slips when cutting. Overheats or bogs down in the cut.	<ol style="list-style-type: none"> <li>1. Excessive depth of cut.</li> <li>2. RPM or feed rate wrong for operation</li> <li>3. Dull cutting bit</li> <li>4. Belt is slipping</li> <li>5. Belt is at fault.</li> </ol>	<ol style="list-style-type: none"> <li>1. Decrease depth of cut.</li> <li>2. Refer to RPM feed rate chart for appropriate Speed or feed.</li> <li>3. Sharpen or replace cutting bit.</li> <li>4. Remove grease or oil from belt. Adjust belts.</li> <li>5. Replace belts.</li> </ol>
Gear change lever will not shift in position	<ol style="list-style-type: none"> <li>1. Gears not aligned in the headstock.</li> </ol>	<ol style="list-style-type: none"> <li>1. Rotate the spindle by hand until the gear falls into place.</li> </ol>
Loud noise coming from machine at the rear near motor	<ol style="list-style-type: none"> <li>1. Pulley set screw or keys are missing or loose.</li> </ol>	<ol style="list-style-type: none"> <li>1. Inspect keys and set screws. Replace or tighten if required.</li> </ol>
Entire machine vibrates excessively upon start-up or while running	<ol style="list-style-type: none"> <li>1. Workpiece is unbalanced.</li> <li>2. Worn or broken gear present.</li> <li>3. Chuck or faceplate has become unbalanced.</li> <li>4. Spindle bearings at fault.</li> </ol>	<ol style="list-style-type: none"> <li>1. Reinstall work piece so it is as centred with spindle centreline.</li> <li>2. Inspect gears and replace if required.</li> <li>3. Rebalance chuck or faceplate. Contact a machine shop for help.</li> <li>4. Adjust or replace spindle bearings</li> </ol>
Cutting tool or machine components vibrate excessively during machining.	<ol style="list-style-type: none"> <li>1. Tool holder not tight enough</li> <li>2. Cutting tool stick out too far out of the tool holder. Lack of support.</li> <li>3. Gibbs out of adjustment.</li> <li>4. Dull cutting tool.</li> <li>5. Incorrect spindle speed or feed rate.</li> </ol>	<ol style="list-style-type: none"> <li>1. Check for debris, clean and re tighten.</li> <li>2. Reinstall cutting tool so that no more than <math>\frac{1}{3}</math> of the total length is sticking out of the toolholder.</li> <li>3. Tighten gib screws on effected slide.</li> <li>4. Replace or sharpen the cutting tool.</li> <li>5. Use the recommended speed and feeds.</li> </ol>
Can't remove the tapered tool from the tailstock quill.	<ol style="list-style-type: none"> <li>1. Quill has not retracted all the way back into the tailstock.</li> <li>2. Debris is binding arbor in the quill.</li> <li>3. Incorrect arbor or tooling inserted into the quill.</li> </ol>	<ol style="list-style-type: none"> <li>1. Turn the quill handwheel until it forces the taper out of the quill.</li> <li>2. Extend quill to exposed drift slot and use drift key to remove arbor.</li> <li>3. Remove quill and drive out tooling or arbor with punch</li> </ol>
Cross slide, compound rest or carriage feed have sloppy operation.	<ol style="list-style-type: none"> <li>1. Gibbs out of adjustment.</li> <li>2. Handwheel is loose or has excessive backlash</li> <li>3. Leadscrew mechanism worn out or out of adjustment.</li> </ol>	<ol style="list-style-type: none"> <li>1. Tighten gibs</li> <li>2. Tighten screws and adjust backlash.</li> <li>3. Tighten any loose fasteners or leadscrew mechanism.</li> </ol>
Bad surface finish	<ol style="list-style-type: none"> <li>1. Wrong RPM or feed rate</li> <li>2. Dull tooling or poor tool selection</li> <li>3. Too much play in the gibs</li> <li>4. Tool too high.</li> </ol>	<ol style="list-style-type: none"> <li>1. Adjust to the appropriate RPM or feed rate.</li> <li>2. Sharpen tooling or select a better tool for the operation.</li> <li>3. Tighten gibs.</li> <li>4. Lower the tool position.</li> </ol>

### 6.3 TROUBLESHOOTING Cont.

Symptoms	Possible Cause	Possible Solution
Inaccurate turning results from one end to the other end of the work-piece.	<ol style="list-style-type: none"> <li>1. Head stock and tailstock are not properly aligned.</li> <li>2. Head stock not aligned to the bed.</li> </ol>	<ol style="list-style-type: none"> <li>1. Realign the tailstock to the headstock spindle, bore and centre line.</li> <li>2. Contact your Hafco Metalmaster service centre.</li> </ol>
Chuck jaws won't move or do not move easily.	<ol style="list-style-type: none"> <li>1. Chips lodged in the jaws</li> <li>2. Chuck Scroll binding.</li> </ol>	<ol style="list-style-type: none"> <li>1. Remove jaws and clean and lubricate chuck threads and replace jaws.</li> <li>2. Remove the chuck and dismantle. Clean with kerosene lubricate and re assemble</li> </ol>
Carriage won't auto feed or overloads the spindle motor.	<ol style="list-style-type: none"> <li>1. Carriage or gib lock is applied.</li> <li>2. Gears are not all en-gauged or broken.</li> <li>3. Gibs are too tight.</li> <li>4. Leadscrew shear pin has sheared.</li> </ol>	<ol style="list-style-type: none"> <li>1. Release locks</li> <li>2. Adjust gear positions or replace.</li> <li>3. Loosen gib screws lightly.</li> <li>4. Correct the cause of the shear pin breakage and replace shear pin.</li> </ol>
Tail stock quill will not feed out	<ol style="list-style-type: none"> <li>1. Quill lock lever is tightened down</li> </ol>	<ol style="list-style-type: none"> <li>1. Turn lever counter clockwise.</li> </ol>

### 6.4 ADJUSTMENTS

#### Tapered Gib Adjustment

Tapered gibs are fitted to the slide ways of the saddle, cross-slide and top (compound) slides so that if any slackness, that may develop can be reduced. Make sure that slide ways are thoroughly cleaned and lubricated before attempting adjustment.

#### To adjust the top slide gib:

1. DISCONNECT MACHINE FROM POWER.
2. Release the rear gib screw and tightening the front screw a little at a time. Check constantly for a smooth action throughout the full slide travel. (Fig. 6.10)

#### To adjust the cross slide gib:

1. DISCONNECT MACHINE FROM POWER.
2. Undo the three button head screws that hold the slide wiper and remove the rubber wiper.
3. Release the rear gib screw and tightening the front screw a little at a time. Check constantly for a smooth action throughout the full slide travel.

#### To adjust the saddle slide gib:

1. Loosen the jam nuts on the four set screws Fig. 6.11), and adjust the set screws.
2. Repeat adjustments as necessary until the carriage adjustment is acceptable.
6. Hold the set screws in place and tighten the jam nuts.

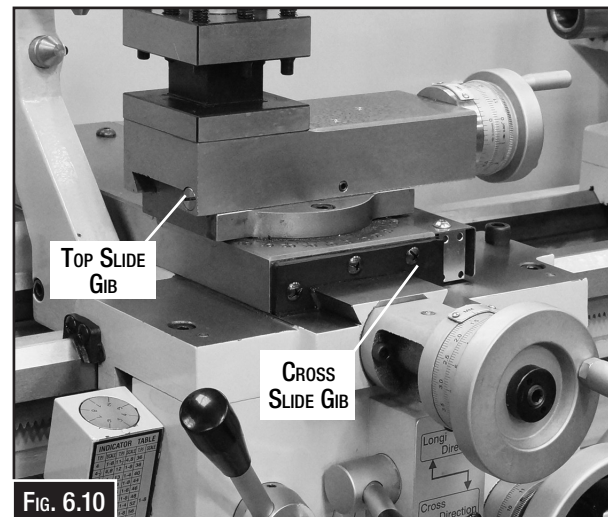

FIG. 6.10

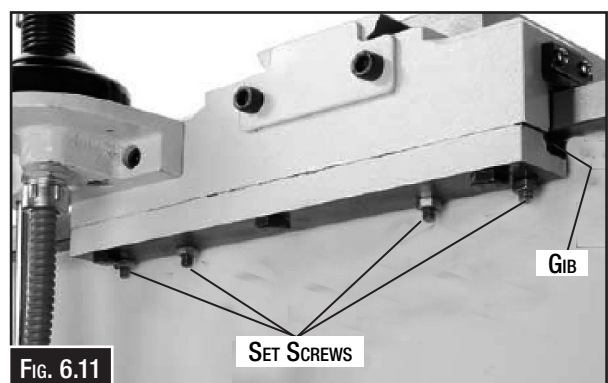

FIG. 6.11

**NOTE: Avoid over adjustment, which can result in an increased wear rate and stiff or jerky action of the movement.**

### Cross Slide Nut Adjustment.

This is an adjustment that can be made to eliminate excessive backlash, which may develop over time.

Backlash is reduced through the cap head screw located at the rear of the nut.

#### To adjust the backlash:

1. DISCONNECT THE MACHINE FROM THE POWER SUPPLY.
2. Remove the back splash guard.
3. With a long hex key in the cap head screw, make only small adjustment. Operating the cross slide several times by hand to be sure of smooth operation throughout the travel. (Fig. 6.12)

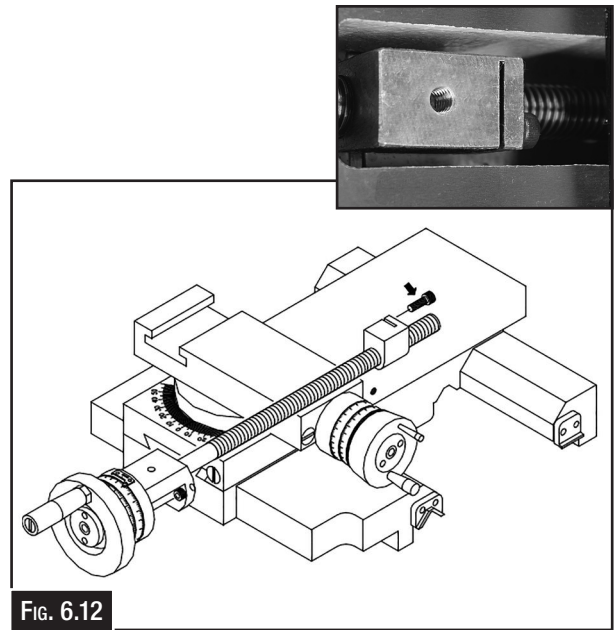

FIG. 6.12

### Feed clutch adjustment

This lathe is equipped with a feed rod clutch, shown in Fig. 6.13, that connects the feed drive hub with the feed rod through a set of spring-loaded internal balls. This clutch helps protect the apron feed system from overload. The feed rod clutch comes set from the factory, and should need no adjustment.

The clutch may slip if the path for the carriage or the cross feed is obstructed during turning or facing operations, the tool bit crashes into a workpiece shoulder, or if the carriage lock is left applied. It is important to recognize, the clutch is not a foolproof way to protecting the lathe from damage if an operational mistake is made. Never completely tighten the feed clutch set screw past its normal setting outlined in this procedure in an attempt to completely eliminate clutch slip. Doing so will void the warranty, and can lead to catastrophic gearbox damage.

#### To adjust the feed rod clutch:

DISCONNECT LATHE FROM POWER!

- if the clutch slips during normal work loads and no problem exists with the feed system, the clutch spring pressure must be increased. Tighten the two set screws 1/8-turn and recheck for slippage.
- if for any reason the clutch is bound up or locked, and does not slip when it should, the clutch spring pressure must be reduced. Loosen the two set screws 1/8-turn, and recheck for slippage.

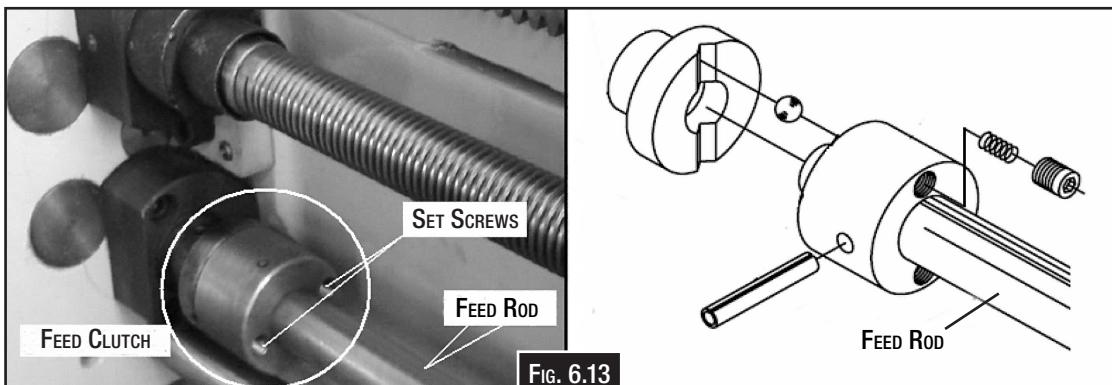

FIG. 6.13

## V-Belt Tension

After initial break in, the v-belts slightly stretch and seat into the pulley. It is important to check and adjust them to compensate for this initial wear. Check the tension thereafter on a monthly basis.

### To check the v-belt tension:

1. Disconnect lathe from power!
2. Open the headstock gear door.
3. Push the center of the v-belts with moderate pressure. The V-belt deflection should be approximately 10mm.
  - if the belt deflection is greater than 10mm, use the wrench to loosen the motor mount bolts (Fig. 6.13) and slide the motor downward until the deflection is correct.
4. Tighten the bolts and recheck the belts.

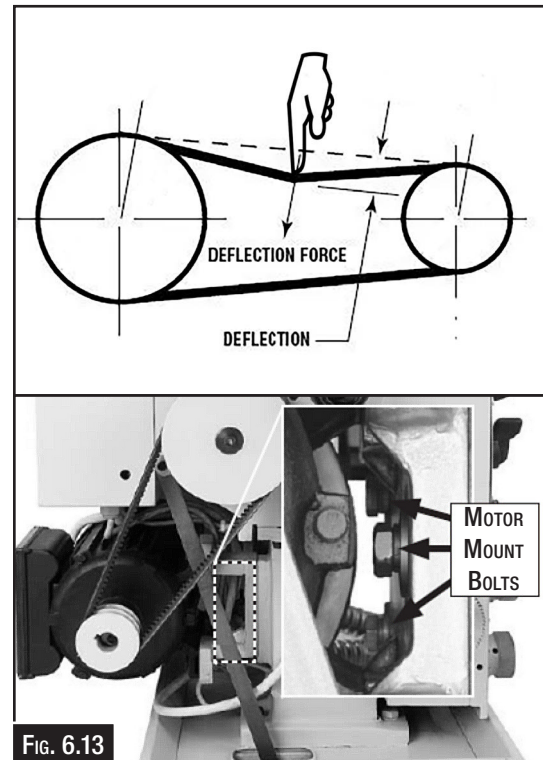

FIG. 6.13

## Half Nut Adjustment

If the half-nut mechanism wears it may have to be adjusted if it becomes loose. The half nut is mounted in ways with a gib exerting pressure between components to reduce sloppy movement. The half-nut gib is a flat bar-type gib, similar to the saddle gib, and is tensioned with three set screws.

### To adjust the half nut:

1. DISCONNECT LATHE FROM POWER!
2. Open the half nut and remove the thread dial.
3. Loosen the hex nuts on the set screws shown in Fig. 6.14.
4. Tighten each set screw approximately 1/8 of a turn, then re tighten the hex nuts without moving the set screws.
5. Move the carriage handwheel until the half nut can fully close, then open/close the half nut several times and notice how it feels. The half nut is correctly adjusted when you feel a slight drag while opening and closing. It should not feel stiff or loose.

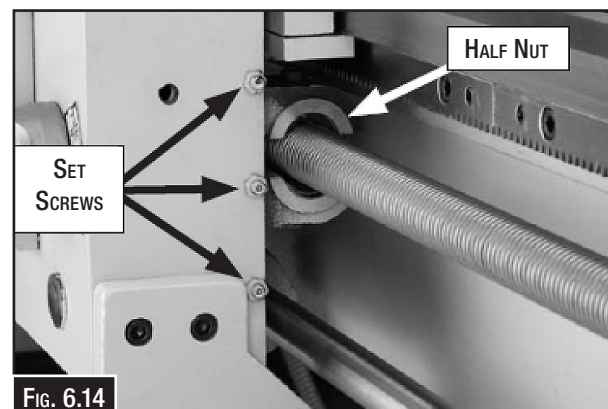

FIG. 6.14

## **CENTRE LATHE AL-356V**

Order Code: (L565D)

Edition : 2.0  
Date: (08/25)

The following section covers the spare parts diagrams and lists that were current at the time this manual was originally printed. Due to continuous improvements of the machine, changes may be made at anytime without notification.

### **HOW TO ORDER SPARE PARTS**

1. Have your machines model number, serial number & date of manufacture on hand, these can be found on the specification plate mounted on the machine.
2. A scanned copy of your parts list/diagram with required spare part/s identified.

### **NOTE: SOME PARTS MAY ONLY BE AVAILABLE AS AN ASSEMBLY**

3. Go to [www.machineryhouse.com.au/contactus](http://www.machineryhouse.com.au/contactus) and fill out the inquiry form attaching a copy of scanned parts list.



### **WARNING!**

*Electricity is dangerous and could cause death  
All electrical work must be carried out by a qualified electrician.*



### **CAUTION!**

*It is impossible to cover all possible hazards Every workshop environment is different. These are designed as a guide to be used to compliment training and as a reminder to users prior to equipment use. Always consider safety first, as it applies to the individual working conditions.*

BED ASSEMBLY 1/2 - DIAGRAM

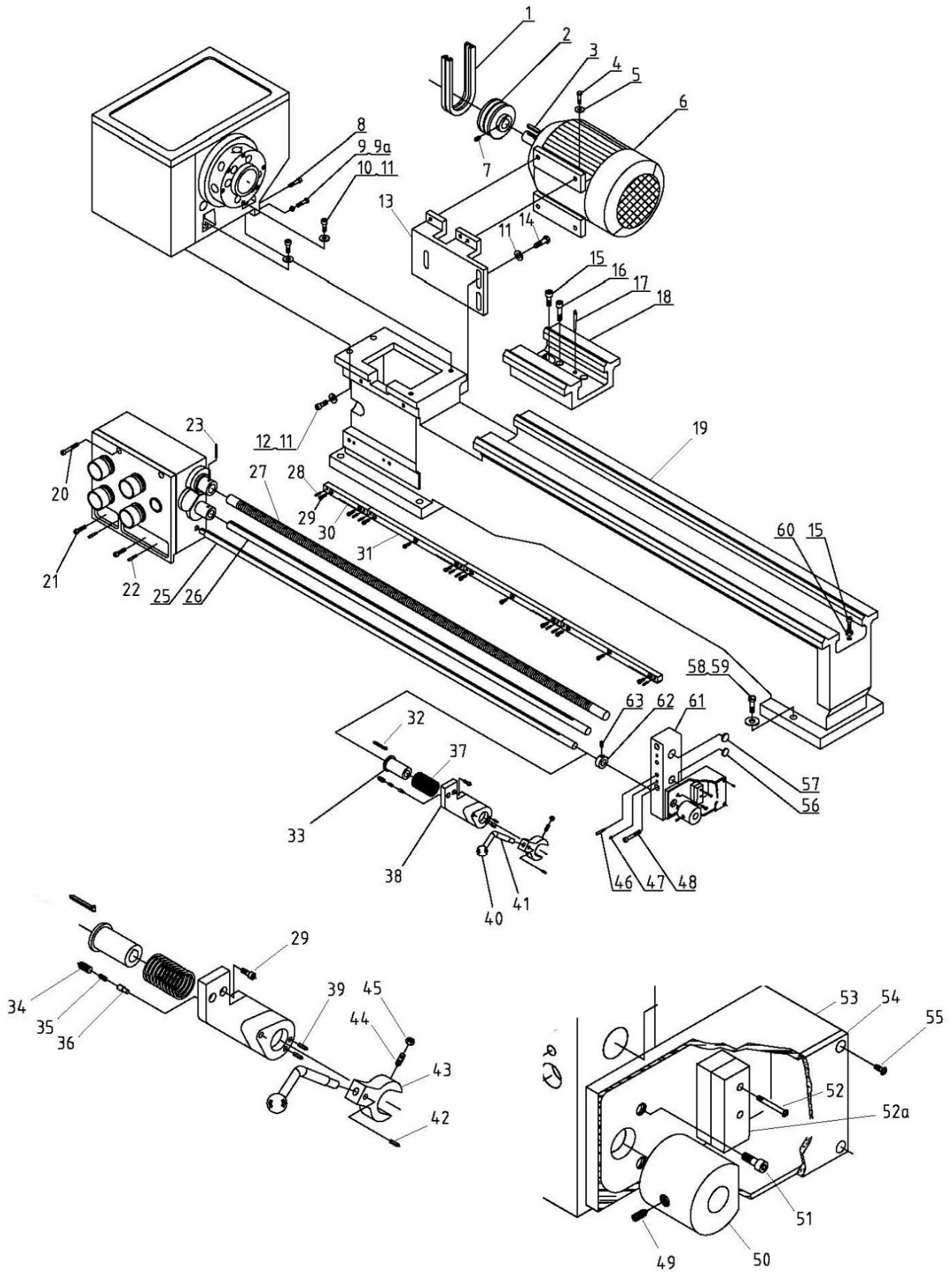

### BED ASSEMBLY 1/2 - PARTS LIST

INDEX NO	PART NO	DESCRIPTION	SIZE	QTY
1		V-BELT	AV13X895	2
2	D330A-11106	PULLEY		1
3	GB1096	KEY	8x35	1
4	GB5781	SCREW	M8x25	4
5	GB97.1	WASHER	8	4
6		MOTOR	1.5 KW	1
7	GB78	SCREW	M6x8	1
8	GB70	HEX SOCKET CAP SCREW	M8x30	2
9	GB5781	SCREW	M8x45	2
9A	GB6170	NUT	M8	2
10	GB70	HEX SOCKET CAP SCREW	M10x35	2
11	GB97.1	WASHER	10	7
12	GB5781	SCREW	M10x40	2
13	D330B-11107G	BRACKET		1
14	GB5781	SCREW	M10x30	3
15	GB70	HEX SOCKET CAP SCREW	M10x35	2
16	GB70	HEX SOCKET CAP SCREW	M12x40	4
17	GB881	ASSEMBLING PIN	8X70	2
18	D330B-11103G	BRIDE		1
19	D330B-11101G	BED		1
20	GB70	HEX SOCKET CAP SCREW	M8x50	2
21	GB70	HEX SOCKET CAP SCREW	M8x30	2
22	GB118	TAPER PIN	6x30	2
23	GB879	PIN	4x36	2
24	GB879	PIN	4x32	1
25	D330B-11203G	CONTROL ROD		1
26	D330B-11202G	FEED ROD		1
27	D330B-11201G	LEADSCREW		1
28	GB879	PIN	5x20	8
29	GB70	HEX SOCKET CAP SCREW	M6x16	13
30	D330B-11205G	SHORT RACK		1
31	D330B-11204G	LONG RACK		3
32	GB1096	KEY	4x50	1
33	D330B-11217G	COLLAR		1
34	GB77	SCREW	M8x8	1
35		SPRING	6x1x15	1
36	D330B-11105G-1	ASSEMBLING PIN		1
37		SPRING	32x3.6x50	1
38	D330B-11105G	BRACKET		1
39	GB879	PIN	5x20	2
40		KNOB	BM10x32	1

**NOTE: SOME INDIVIDUAL PARTS MAY ONLY BE AVAILABLE AS AN ASSEMBLY**

**BED ASSEMBLY 1/2 - PARTS LIST CONT.**

INDEX NO	PART NO	DESCRIPTION	SIZE	QTY
41	D330B-11206G	LEVER		1
42	GB879	PIN	4x20	1
43	D330B-11104G	BARCKET		1
44	GB78	SCREW	M6x16	2
45	GB6170	NUT	M6	2
46	GB118	TAPER PIN	6x45	2
47	GB7940.4	OIL CUP	6	2
48	GB70	HEX SOCKET CAP SCREW	M8x60	2
49	GB78	SCREW	M8x12	1
50	D330C-3012C	PLEC TRUM		1
51	GB70	HEX SOCKET CAP SCREW	M8x16	2
52	GB818	SCREW	M4x40	2
52A		SWITCH	LXW5-11D1	2
53	D330C-11301C	BOX		1
54	D330C-11302C	COVER		1
55	GB818	SCREW	M4x10	4
56	D330B-11210G-1	COVER	19	1
57	D330B-11210G-2	COVER	22	1
58	GB5781	SCREW	M12x45	6
59	GB97.1	WASHER	12	6
60	GB6170	NUT	M10	1

**NOTE: SOME INDIVIDUAL PARTS MAY ONLY BE AVAILABLE AS AN ASSEMBLY**

**BED ASSEMBLY 2/2 - DIAGRAM**

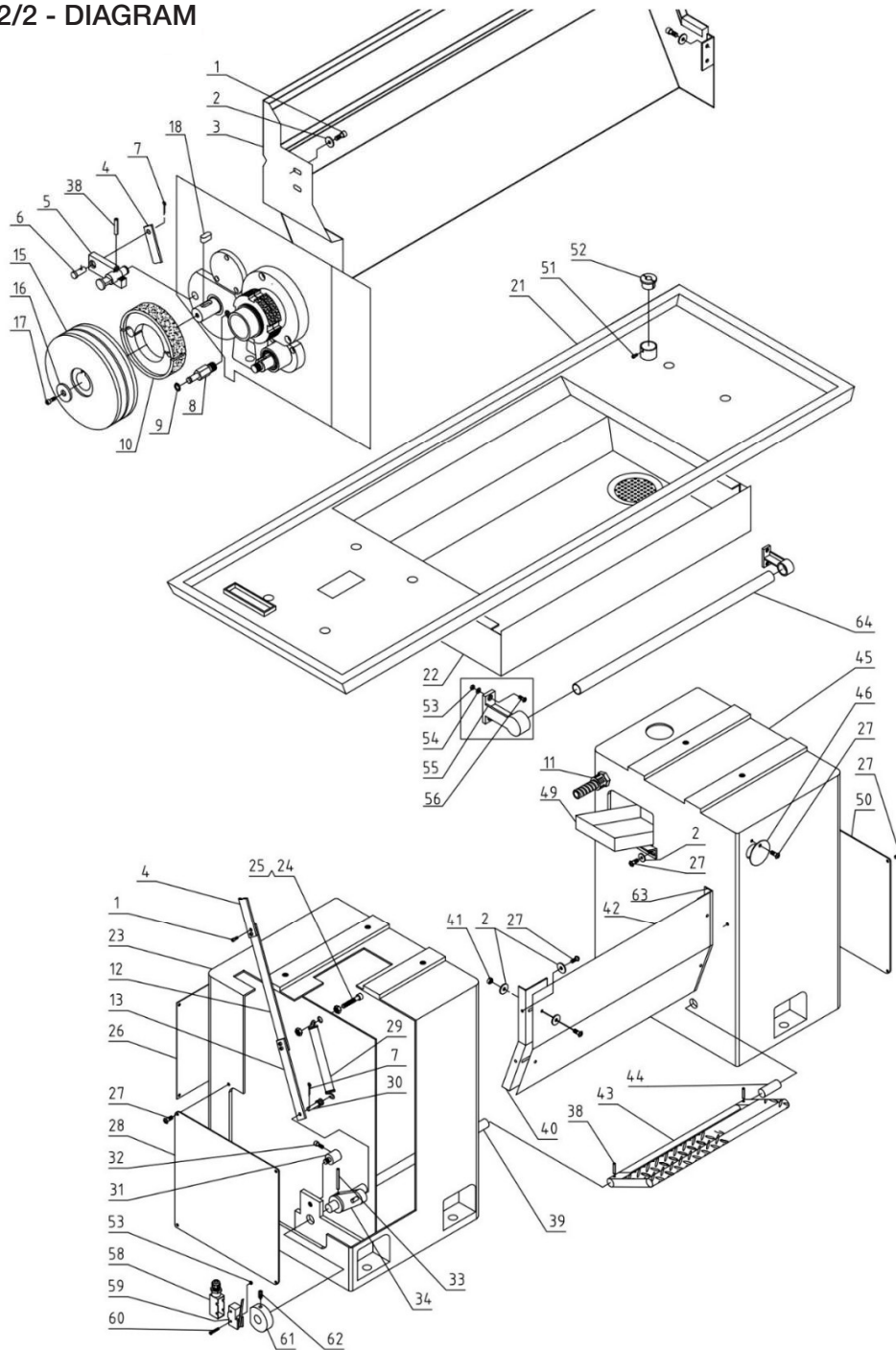

**BED ASSEMBLY 2/2 - PARTS LIST**

INDEX NO	PART NO	DESCRIPTION	SIZE	QTY
1	GB70	SOCKET HEAD SCREW	M6x10	8
2	GB97.1	TAILOR-MADE WASHER	6	18
3	D330B-14205	SPLASH GUARD		1
4	D330B-14214-1	BRAKE LINKAGE/UPPER		1
5	D330B-14218	ROCKER		1
6	D330A-11239	ROCKER SHAFT		1
7	GB91	ROLL PIN	3X16	2
8	D330A-11232	SHAFT		1

**BED ASSEMBLY 2/2 - PARTS LIST CONT.**

INDEX NO	PART NO	DESCRIPTION	SIZE	QTY
9	GB894.1	EXT RETAINING RING	8	1
10		PULLEY BRAKE ASSEMBLY	125X25	1
11		LOCK CONNECTOR	M16X1.5	2
12	D330B-14214-2	BRAKE LINKAGE/MIDDLE		1
13	D330B-14214-3	BRAKE LINKAGE/LOWER		1
15	D330A-21105	PULLEY		1
16	GB97.1	WASHER	8	1
17	GB70	SOCKET HEAD SCREW	M8x16	1
18	GB1096	KEY	8x20	1
21	D330B-14203A	CHIP PAN		1
22	D330B-14204A	REMOVABLE CHIP TRAY		1
23	D330B-14201A	LEFT STAND		1
24	GB70	SOCKET HEAD SCREW	M10x30	1
25	GB6170	HEX NUT	M10	2
26	D330A-14210A	LEFT STAND REAR COVER		1
27	GB818	PAN HEAD SCREW	M6X10	26
28	D330A-14209A	LEFT STAND SIDE COVER		1
29	D330A-11237	EXTENSION SPRING		1
30	D330A-11236	PIN		1
31	D330A-11242	SHAFT		1
32	GB70	SOCKET HEAD SCREW	M6x40	1
33	GB879	ROLL PIN	5x40	1
34	D330A-11235	ROCKER		1
38	GB879	ROLL PINROLL PIN	5x28	3
39	D330B-14215	SHAFT		1
40	D330B-14206	LEFT BRACKET		1
41	GB6170	HEX NUT	M6	4
42	D330B-14207	STAND PLATE		1
43	D330B-14212	BRAKE PEDAL		1
44	D330B-14216	SHAFT		1
45	D330B-14202A	RIGHT STAND		1
46	D330D-14208B	COVER		4
49	D330D-14213B	COOLANT CHUTE		1
50	D330B-14211A	RIGHT STAND SIDE COVER		1
51	GB70	SOCKET HEAD SCREW	M4x6	1
52	D330A-92206	COLLANT HOSE COLLAR		1
53	GB6170	HEX NUT	M4	4
54	GB97.1	FLATE WASHER	4	4
55		BRACKET		2
56	GB818	SCREW	M4X10	4
58		COVER		1
59		SWITCH	YBLXW-5/11N1	1
60	GB818	SCREW	M4X40	2
61	D330DV-11210	BRAKE DOLLOP		1
62	GB78	SCREW	M6X12	1
63	D330B-14206-1	RIGHT BRACKET		1
64		SHAFT		1

**NOTE: SOME INDIVIDUAL PARTS MAY ONLY BE AVAILABLE AS AN ASSEMBLY**

**HEADSTOCK ASSEMBLY 1/2 - DIAGRAM**

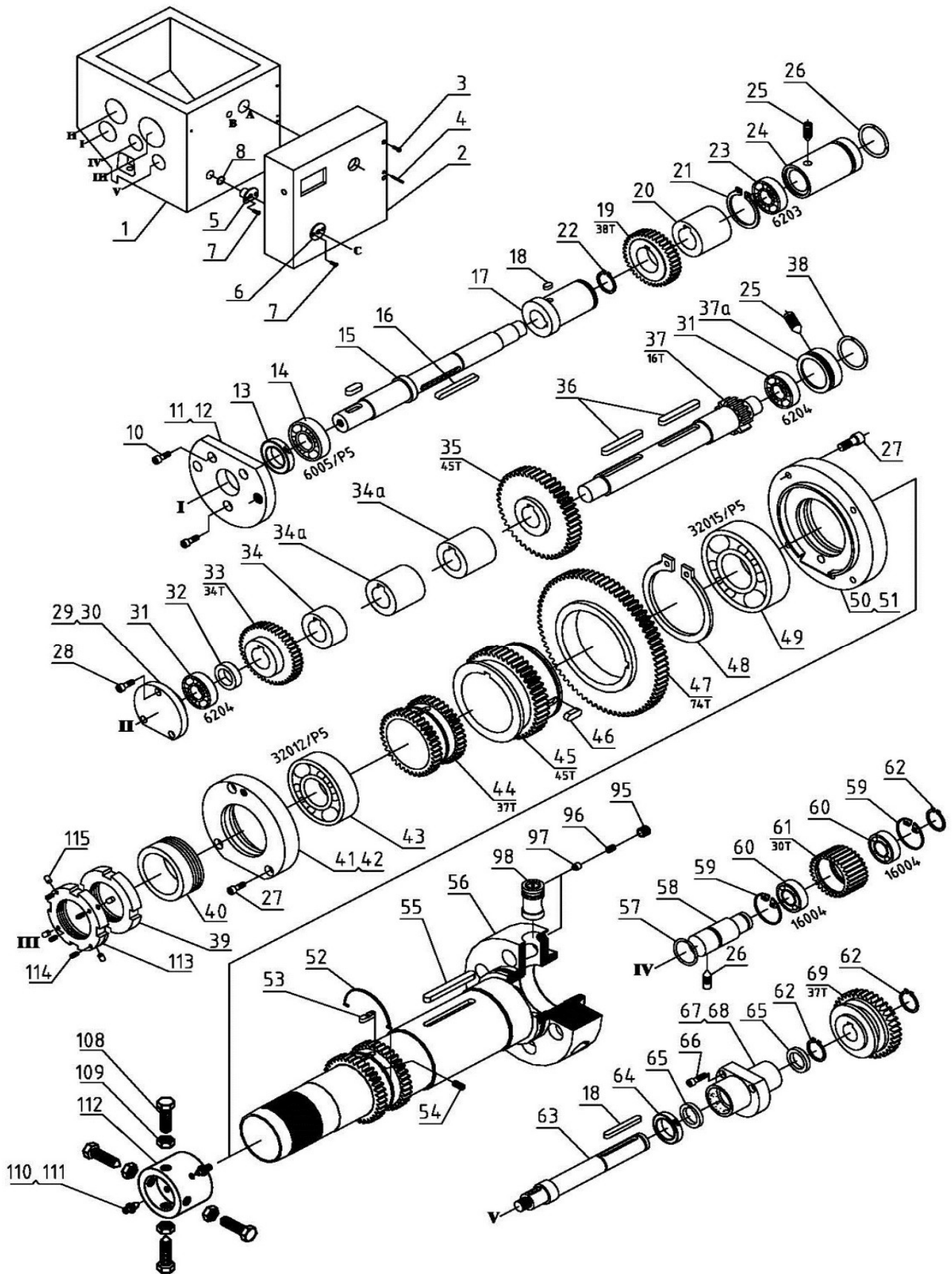

## HEADSTOCK ASSEMBLY 1/2 - PARTS LIST

INDEX NO	PART NO	DESCRIPTION	SIZE	QTY
1	D330D-21107	HEADSTOCK		1
2	D330DV-21113G-2	CASE FRAME		1
3	GB70	SOCKET HEAD SCREW	M6x40	4
4	GB879	SPRING PIN	5x40	2
5	D330A-21246	SLEEVE		1
6	D330A-21235	SLEEVE		1
7	GB819	SCREW	M4x8	4
8	GB1235	O-RING	20x2.65	1
10	GB70	SOCKET HEAD SCREW	M6x20	3
11	D330A-21124	COVER		1
12	D330A-21601	GASKET		1
13	GB3871	OIL SEAL	SD25X40X7	1
14	GB276	RADIAL THRUST BEARING	6005/P5	1
15	D330A-21215	SHAFT		1
16	GB1096	KEY	6x50	1
17	D330DV-21217	WASHER		1
18	GB1096	KEY	6x10	1
19	D330A-21220	GEAR	38T	1
20	D330D-21221	WASHER		1
21	GB894.1	CIRCLIP	35	1
22	GB894.1	CIRCLIP	22	1
23	GB276	RADIAL THRUST BEARING	6203	1
24	D330A-21106	FRONT PLUG		1
25	GB78	SCREW	M8x16	1
26	GB1235	O-RING	40x3.1	1
27	GB70	SOCKET HEAD SCREW	M6x25	7
28	GB70	SOCKET HEAD SCREW	M4x12	3
29	D330A-21104	COVER		1
30	D330A-21602	GASKET		1
31	GB276	RADIAL THRUST BEARING	6204	2
32	D330A-21211	WASHER		1
33	D330D-21223	GEAR	34T	1
34	D330DV-21221	WASHER		1
34A	D330D-21221	WASHER		2
35	D330D-21224	GEAR	45T	1
36	GB1096	KEY	8x55	2
37	D330A-21212	SHAFT	16T	1
37A	D330A-21225	PLUG		1
38	GB1235	O-RING	47x3.1	1
39	D330D-21208	NUT		1
40	D330D-21102	COLLAR		1
41	D330D-21103	END COVER		1
42	D330D-21603	GASKET		1
43	GB297	RADIAL THRUST BEARING	32012/P5	1
44	D330D-21207	GEAR	37T	1
45	D330D-21227	GEAR	45T	1
46	GB1096	KEY	8x18	1

**NOTE: SOME INDIVIDUAL PARTS MAY ONLY BE AVAILABLE AS AN ASSEMBLY**

## HEADSTOCK ASSEMBLY 1/2 - PARTS LIST CONT.

INDEX NO	PART NO	DESCRIPTION	SIZE	QTY
47	D330D-21226	GEAR	74T	1
48	GB894.1	CIRCLIP	90	1
49	GB297	RADIAL THRUST BEARING	32015/P5	1
50	D330D-21108	FRONT COVER		1
51	D330D-21605	GASKET		1
52	D330D-21252	TAILOR-MADE RING SPRING		1
53	D330D-21251	TAILOR-MADE KEY	6x18	1
54	GB73	SCREW	M6x8	1
55	GB1096	KEY	8x85	1
56	D330D-21228	SPINDLE		1
57	GB1235	O-RING	25x2.4	1
58	D330A-21238	SHAFT		1
59	GB893.1	CIRCLIP	42	2
60	GB276	RADIAL THRUST BEARING	16004	2
61	D330A-21237	GEAR	30T	1
62	GB894.1	CIRCLIP	20	2
63	D330B-21239G	SHAFT		1
64	GB3871	OIL SEAL	24x32x5	1
65	D330A21202	WASHER		2
66	GB70	SOCKET HEAD SCREW	M5x16	3
67	D330A-21101	COLLAR		1
68	D330A-21604	GASKET		1
69	D330A-21201	GEAR	37T	1
95	D330D-21250	SCREW BUSHING		6
96	D330D-21254	SPRING		6
97	D330D-21253	ARRESTING PIN		6
98	D330D-21231	CAM		6
108	D330D-21302	SPIDER SCREW M10-1.5 X 33		4 (OPTIONAL)
109	GB6172	HEX NUT	M10	4 (OPTIONAL)
110	GB78	SET SCREW	M6X16	2 (OPTIONAL)
111	GB6170	HEX NUT	M6	2 (OPTIONAL)
112	D330D-21301	SPIDER SLEEVE		1 (OPTIONAL)
113	D330DV-21208	NUT		1
114	GB77	SCREW	M4X6	4
115		MAGNET	Ø5X7	4

**NOTE: SOME INDIVIDUAL PARTS MAY ONLY BE AVAILABLE AS AN ASSEMBLY**

**HEADSTOCK ASSEMBLY 2/2 - DIAGRAM**

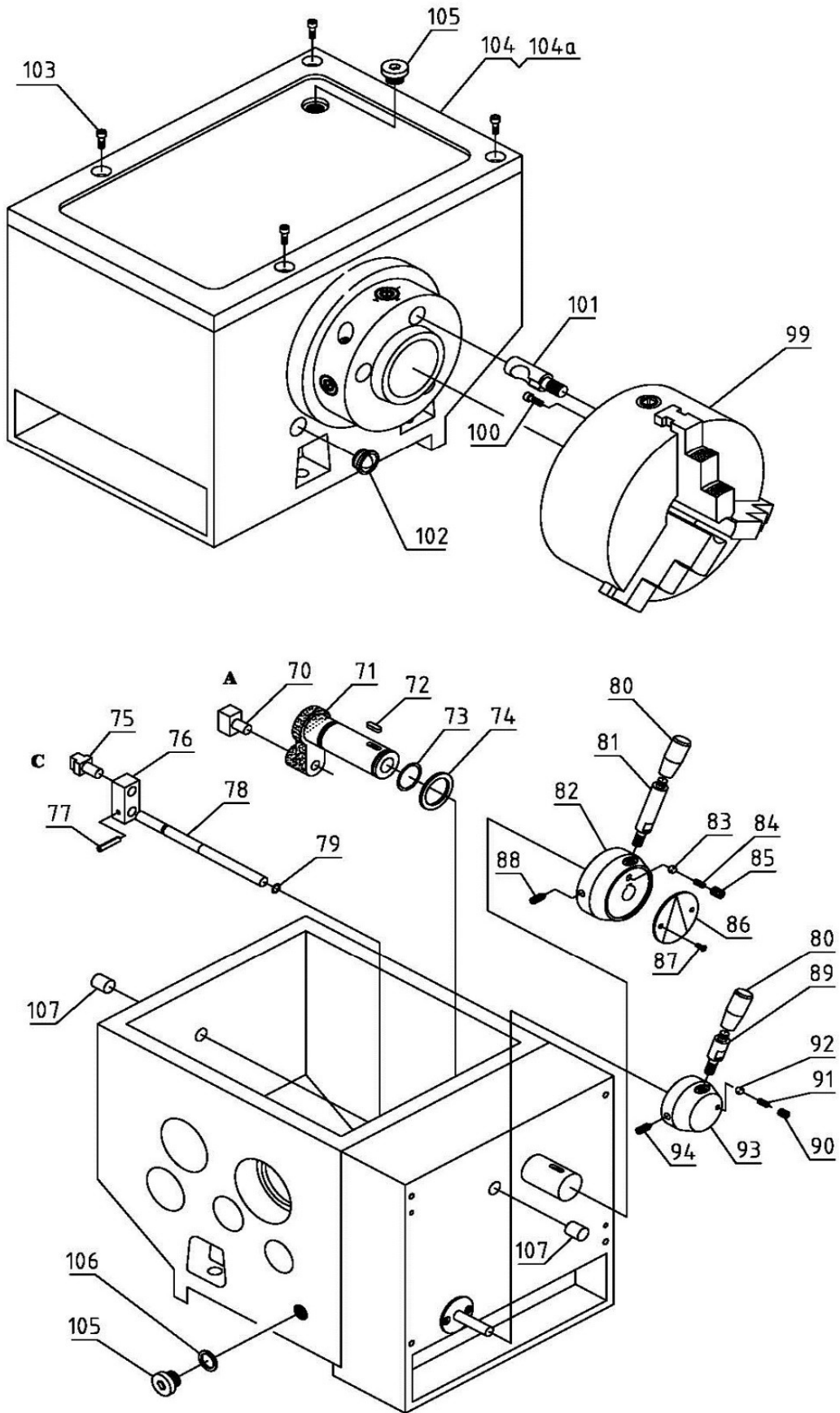

## HEADSTOCK ASSEMBLY 2/2 PARTS LIST

INDEX NO	PART NO	DESCRIPTION	SIZE	QTY
70	D330A-21403	SHIFT FORK		1
71	D330D-21121	SHIFT COLLAR		1
72	GB1096	KEY	5x14	1
73	GB1235	O-RING	30x3.1	1
74	D330A-21240	WASHER		1
75	D330A-21402	SHIFT FORK		1
76	D330A-21111	ROCKER		1
77	GB879	SPRING PIN	4x18	1
78	D330B-21236G	SHAFT		1
79	GB1235	O-RING	10x1.9	1
80	GB7271.3	COVER	BM8x40	2
81	D330A-21249	HANDLE		1
82	D330A-21117	HANDLE BASE		1
83	GB308	STEEL BALL	6	1
84	GB2089	SPRING	Y1-6x1x10	1
85	GB77	SCREW	M8x8	1
86		POSITION SIGN		1
87	GB818	SCREW	M4x8	2
88	GB879	SPRING PIN	4x50	1
89	D330A-21248	HANDLE		1
90	GB77	SCREW	M6x8	1
91	GB2089	SPRING	Y1-5x1x25	1
92	GB308	STEEL BALL	5	1
93	D330A-21120	HANDLE BASE		1
94	GB78	SCREW	M6x16	1
99		THREE JAW CHUCK	D5/200	1
100	GB70	SOCKET HEAD SCREW	M6x20	6
101	D330D-81201	CAM LOCK STUD		6
102	GB1160.1	OIL SIGHT	A12	1
103	GB70	SOCKET HEAD SCREW	M6x25	4
104	D330B-21112G	COVER BOARD		1
104A	D330A-21606	GASKET		1
105		HEXAGONAL SOCKET HEAD PLUG	M16x1.5	1
106		COPPER WASHER	16	1
107	D330DV-21232	PLUG		2

**NOTE: SOME INDIVIDUAL PARTS MAY ONLY BE AVAILABLE AS AN ASSEMBLY**

**GEARBOX ASSEMBLY 1/2 - DIAGRAM**

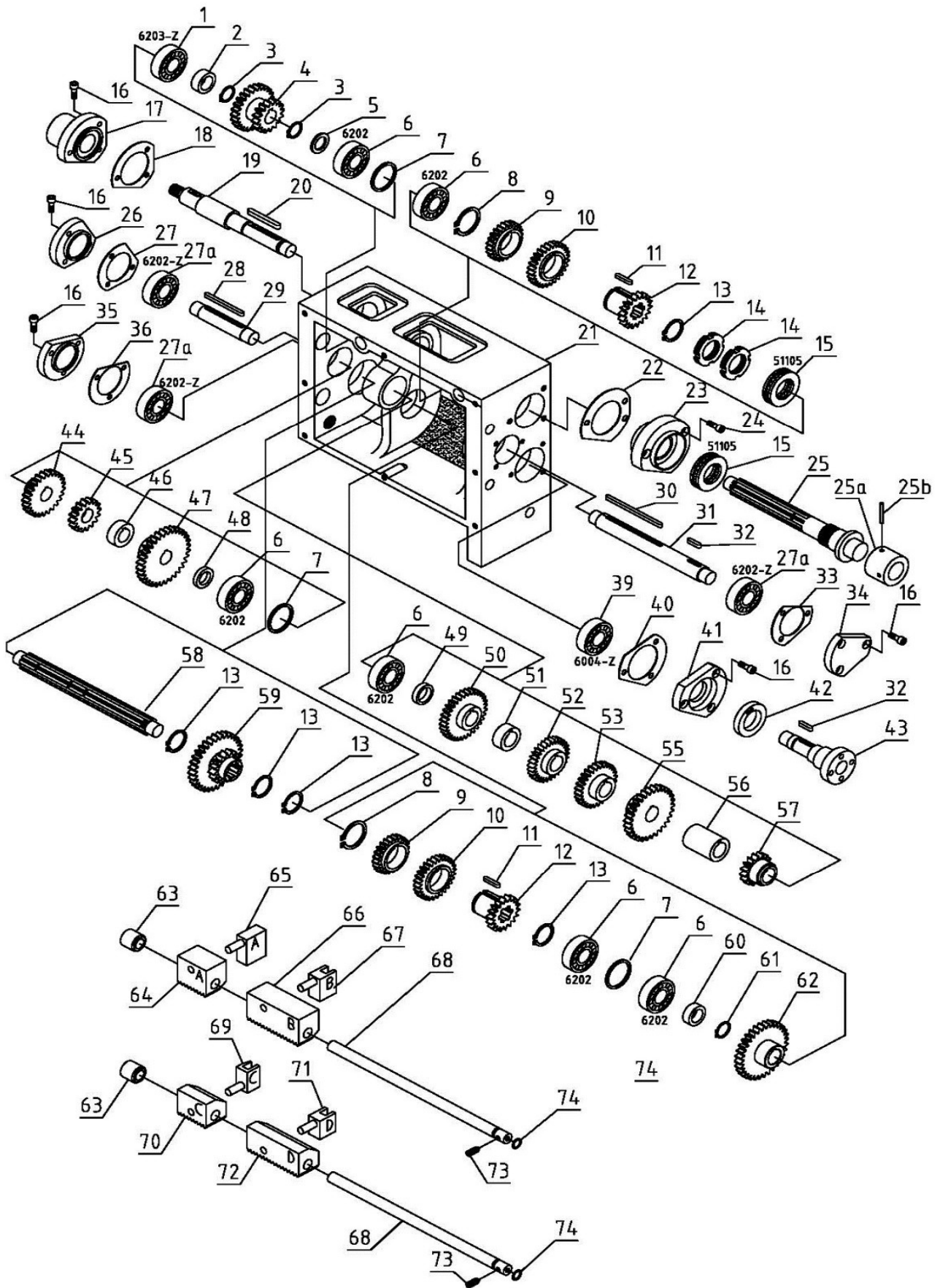

**GEARBOX ASSEMBLY 2/2 - DIAGRAM**

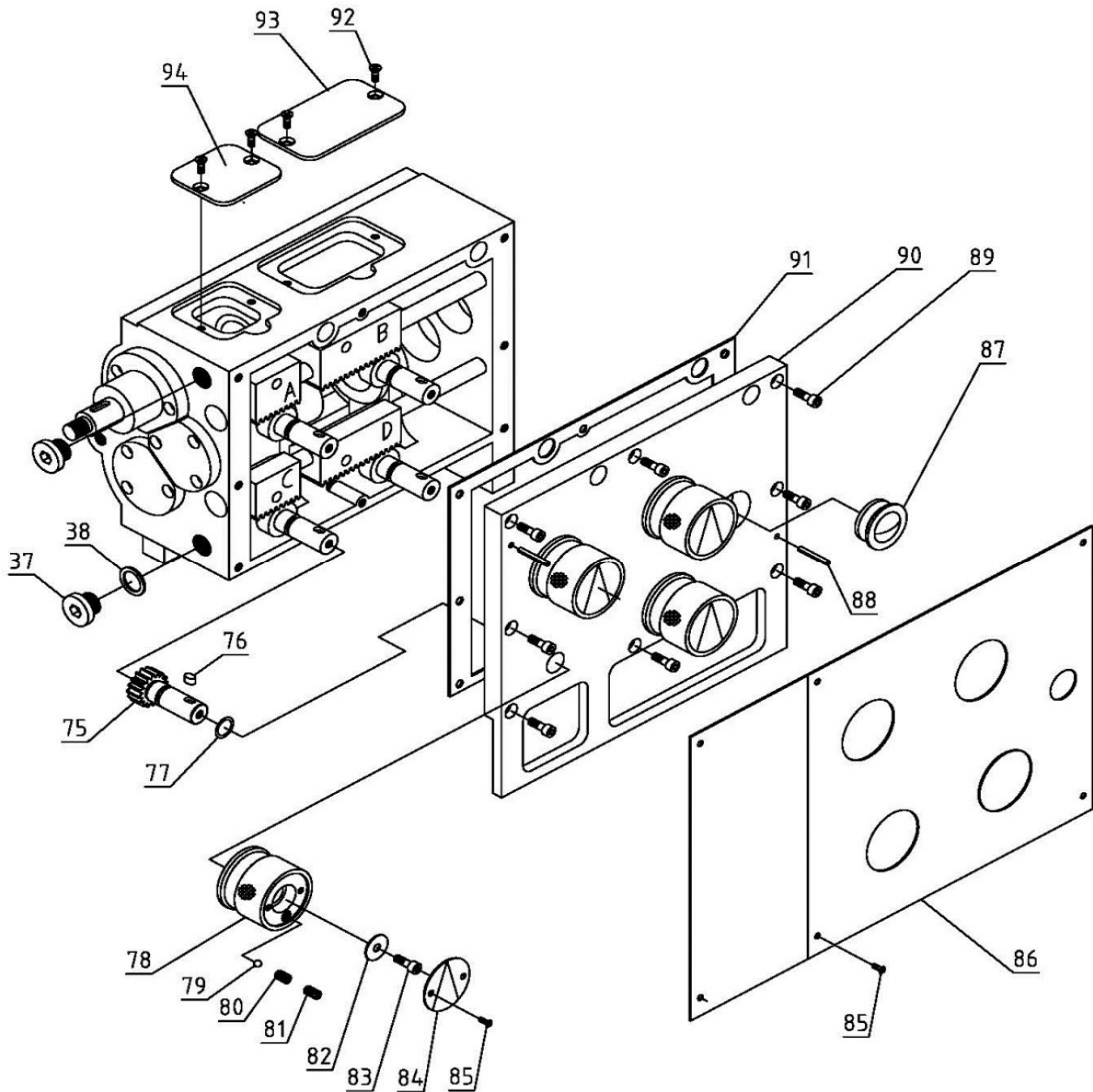

**GEARBOX ASSEMBLY - PARTS LIST**

INDEX NO	PART NO	DESCRIPTION	SIZE	QTY
1	GB276	RADIAL THRUST BEARING	6203	1
2	D330B-31105	SPACE WASHER		1
3	GB894.1	CIRCLIP	16	2
4	D330B-31201	GEAR		1
5	D330B-31106	SPACE WASHER		1
6	GB276	RADIAL THRUST BEARING	6202	6
7	D330B-31107	SPACE WASHER		3
8	GB894.1	CIRCLIP	28	2
9	D330B-34201-3	GEAR		2
10	D330B-34201-2	GEAR		2
11	GB1096	KEY	A4x22	2
12	D330B-34201-1	GEAR		2

## GEARBOX ASSEMBLY - PARTS LIST CONT...

INDEX NO	PART NO	DESCRIPTION	SIZE	QTY
13	GB894.1	CIRCLIP	20	5
14	D330C-0546C	CIRCLE NUT		2
15	GB301	THRUST BALL BEARING	51105	2
16	GB70	SOCKET HEAD SCREW	M5x14	15
17	D330B-31102-0	FLANGE		1
18	D330B-31103	GASKET		1
19	D330B-31101	SHAFT		1
20	GB1096	KEY	5x45	1
21	D330B-30101	CASTING CASE		1
22	D330B-37103-0	GASKET		1
23	D330B-37102-0	BUSH		1
24	GB70	SOCKET HEAD SCREW	M6x14	3
25	D330B-37101-0	SHAFT		1
25A	D330B-37101-2	COUPLER SLEEVE		1
25B	GB879	ROLL PIN	4X35	1
26	D330B-32102	END COVER		1
27	D330B-32103	GASKET		1
27A	GB276	BEARING	6202	3
28	GB1096	KEY	4x55	1
29	D330B-32101	SHAFT		1
30	GB1096	KEY	4x80	1
31	D330B-35101	SHAFT		1
32	GB1096	KEY	4x18	2
33	D330B-35103	GASKET		1
34	D330B-35102	END COVER		1
35	D330B-33102	END COVER		1
36	D330B-33103	GASKET		1
37		HEXAGONAL SOCKET HEAD PLUG	M16x1.5	2
38		COPPER WASHER	16	1
39	GB276	RADIAL THRUST BALL BEARING	6004	1
40	D330B-36103	GASKET		1
41	D330B-36102	FLANGE		1
42	GB3871	OIL SEAL	SD25X40X7	1
43	D330B-36101	SHAFT		1
44	D330B-32201	GEAR		1
45	D330B-32202	GEAR		1
46	D330B-32104	SPACE WASHER		1
47	D330B-32203	GEAR		1
48	D330B-32105	SPACE WASHER		1
49	D330B-35106	SPACE WASHER		1
50	D330B-35205	GEAR		1
51	D330B-35105	SPACE WASHER		1
52	D330B-35204	GEAR		1
53	D330B-35203	GEAR		1
55	D330B-35202	GEAR		1
56	D330B-35104	SPACE WASHER		1
57	D330B-35201	GEAR		1

**NOTE: SOME INDIVIDUAL PARTS MAY ONLY BE AVAILABLE AS AN ASSEMBLY**

## GEARBOX ASSEMBLY - PARTS LIST CONT...

INDEX NO	PART NO	DESCRIPTION	SIZE	QTY
58	D330B-33101	SHAFT		1
59	D330B-33201	GEAR		1
60	D330B-36104	SPACE WASHER		1
61	GB894.1	CIRCLIP	16	1
62	D330B-36201	GEAR		1
63	D330B-38102	END COVER		2
64	D330B-38103	RACK-A		1
65	D330B-38104	SHIFT FORK-A		1
66	D330B-38105	RACK-B		1
67	D330B-38106	SHIFT FORK-B		1
68	D330B-38101	SHAFT		2
69	D330B-38108	SHIFT FORK-C		1
70	D330B-38107	RACK-C		1
71	D330B-38110	SHIFT FORK-D		1
72	D330B-38109	RACK-D		1
73	GB78	SCREW	M5x8	2
74	GB1235	O-RING	12x1.9	2
75	D330B-38111	GEAR		4
76	GB1096	KEY	5x8	4
77	GB1235	O-RING	16x2.4	4
78	D330A-3054	HANDLE		4
79	GB308	STEEL BALL	6	4
80	GB2089	SPRING	Y1-6x1x25	4
81	GB77	SCREW	M8x8	4
82	GB97.1	WASHER	6	4
83	GB70	SOCKET HEAD SCREW	M6x12	4
84		POSITION SIGN		4
85	GB818	SCREW	M4x6	14
86		GEARBOX PLATE		1
87	GB1160.1	OIL SIGHT	A16	1
88	GB879	SPRING PIN	4x25	2
89	GB70	SOCKET HEAD SCREW	M6x20	8
90	D330B-38112	COVER		1
91	D330B-38113	GASKET		1
92	GB819	SCREW	M4x6	4
93	D330B-38115	COVER-2		1
94	D330B-38114	COVER-1		1

**NOTE: SOME INDIVIDUAL PARTS MAY ONLY BE AVAILABLE AS AN ASSEMBLY**

**CHANGE GEARBOX - DIAGRAM**

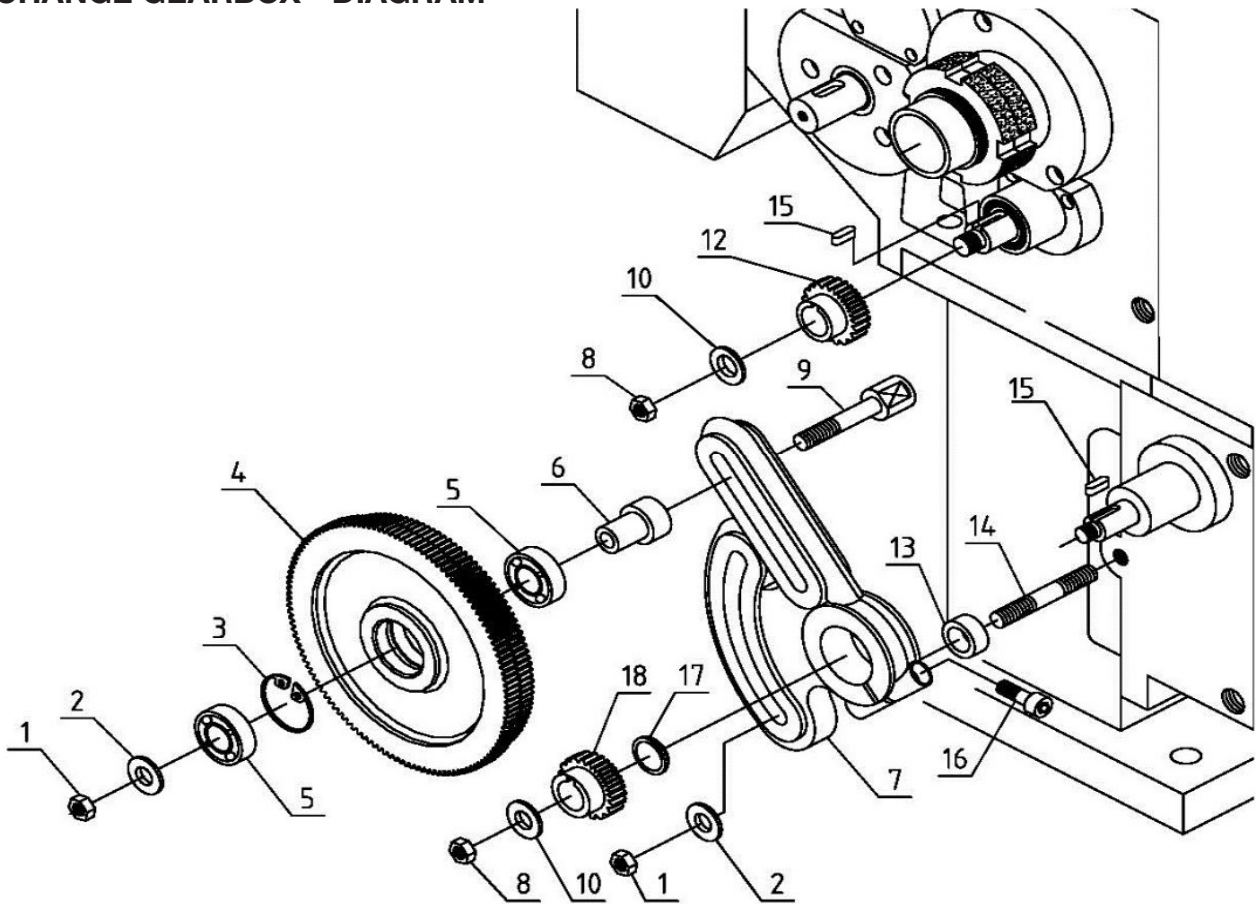

**CHANGE GEARBOX - PARTS LIST**

INDEX NO	PART NO	DESCRIPTION	SIZE	QTY
1	GB6170	NUT	M10	2
2	GB97.1	WASHER	10	2
3	GB893.1	CIRCLIP	35	1
4	D330A-91208	GEAR		1
5	GB276	BEARING	6003-Z	2
6	D330B-91209G	COLLAR		1
7	D330B-91101G	GEAR FRAME		1
8	GB6170	NUT	M12	2
9	D330B-91210G	BOLT		1
10	GB97.1	WASHER	12	2
12	D330B-91201G	GEAR	30T	1
13	D330B-91214G	WASHER		1
14	GB901	DOUBLE-SCREW BOLT	M10x70	1
15	GB1096	KEY	5x14	2
16	GB70	HEX SOCKET CAP SCREW	M8X25	1
17	D330B-91212G	WASHER		1
18	D330B-91202G	GEAR	40T	2
19	D330B-91204G	GEAR	35T	1

**NOTE: SOME INDIVIDUAL PARTS MAY ONLY BE AVAILABLE AS AN ASSEMBLY**

**CHANGE GEARBOX COVER - DIAGRAM**

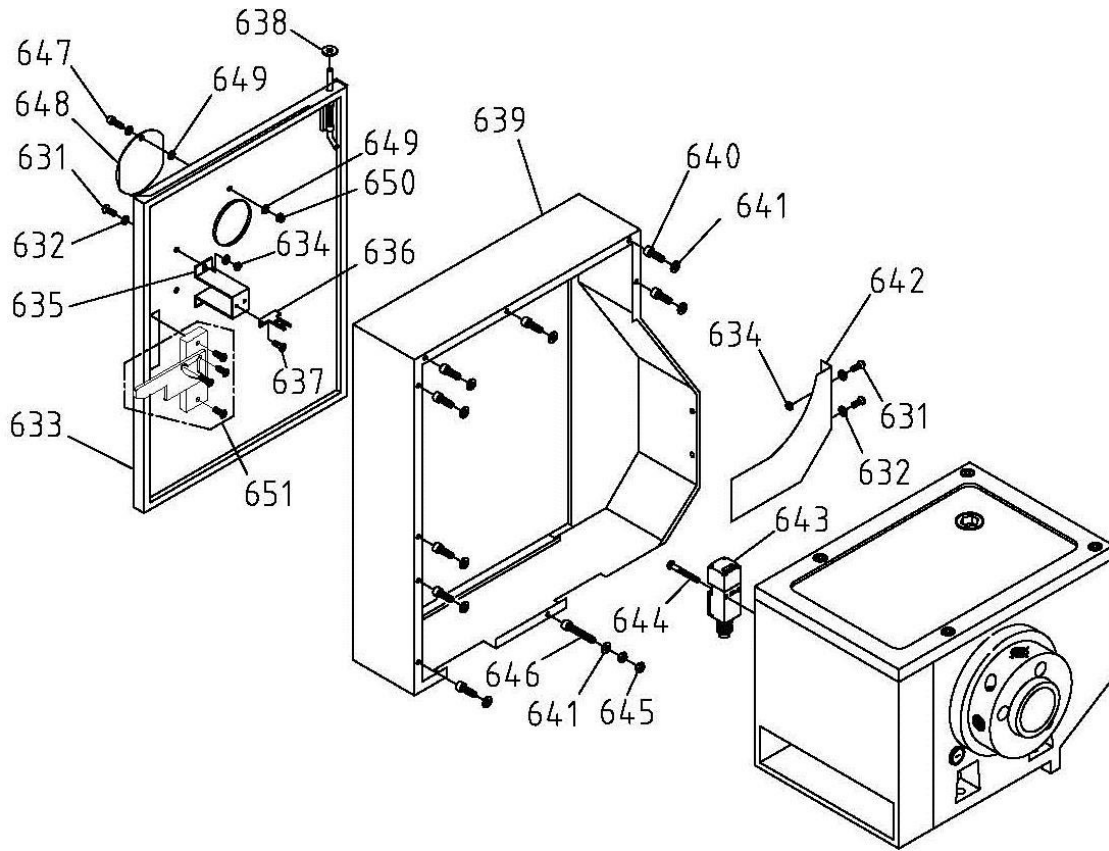

**CHANGE GEARBOX - PARTS LIST**

INDEX NO	PART NO	DESCRIPTION	SIZE	QTY
631	GB818	PAN HEAD SCREW	M4x6	4
632	GB97.1	FLAT WASHER	4	6
633	D360D-13401A-1	DOOR		1
634	GB6175	HEX NUT	M4	4
635	D330A-71209	BRACKET		1
636		SWITCH KEY		1
637	GB818	PAN HEAD SCREW	M4x6	2
638		FLAT WASHER		2
639	D360D-13401A	CHANGE GEAR COVER		1
640	GB70	HEX SOCKET CAP SCREW	M5X8	8
641	GB97.1	FLAT WASHER	5	9
642	D330B-14220	MOTOR COVER		1
643		SWITCH	QKS8	1
644	GB818	PAN HEAD SCREW	M4X30	2
645	GB6175	HEX NUT	M5	2
646	GB70	HEX SOCKET CAP SCREW	M5X50	1
647	GB70	HEX SOCKET CAP SCREW	M6X12	1
648	D330D-14208B-1	DOOR COVER		1
649		HEX LOCK NUT	M6	1
650	GB97.1	FLAT WASHER	6	1
651		DOOR LATCH ASSY		1

**NOTE: SOME INDIVIDUAL PARTS MAY ONLY BE AVAILABLE AS AN ASSEMBLY**

**APRON ASSEMBLY - DIAGRAM**

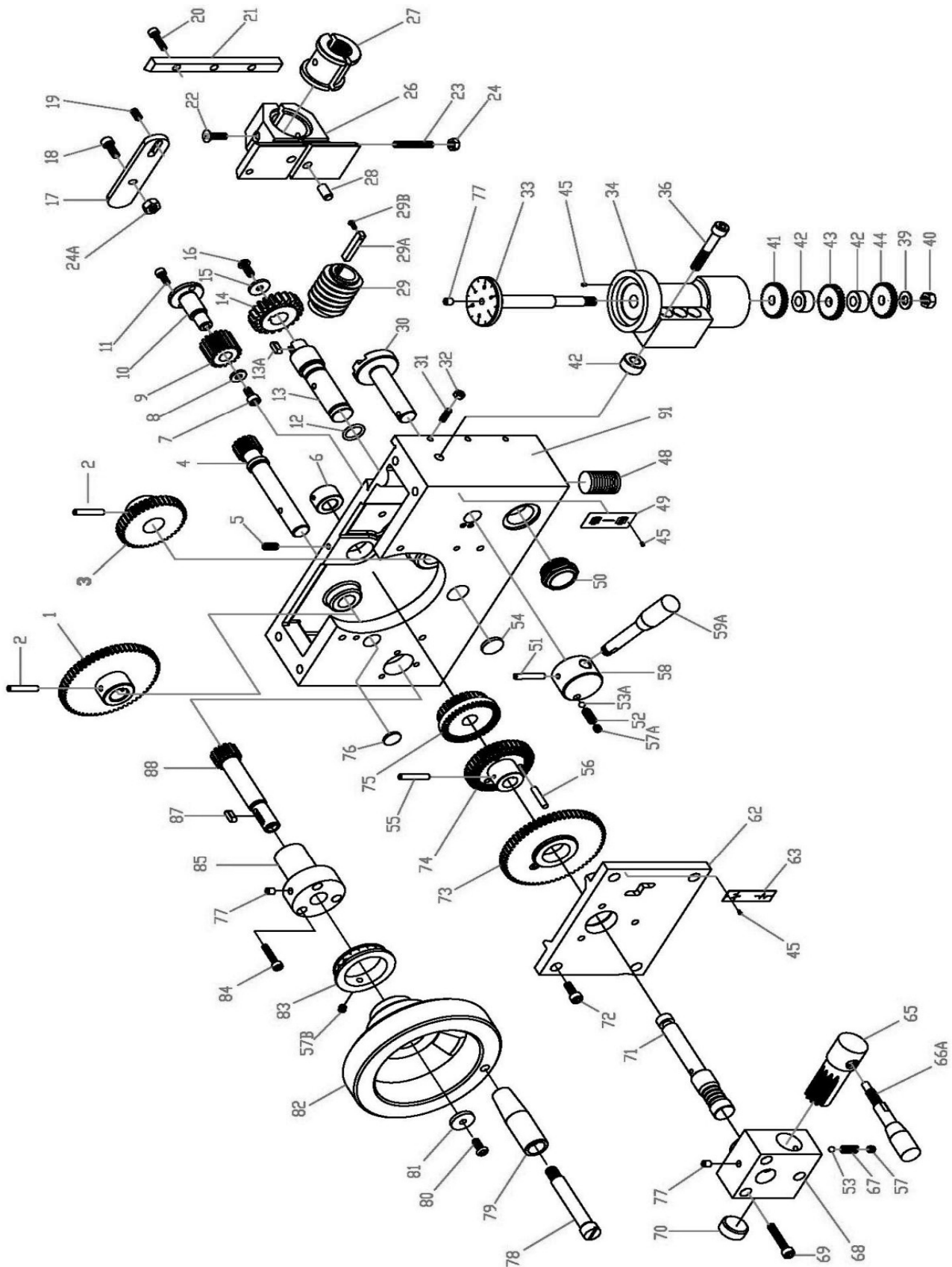

## APRON ASSEMBLY - PARTS LIST

INDEX NO	PART NO	DESCRIPTION	SIZE	QTY
1	33-4012	GEAR	M1.5x60T	1
2	GB879-86	SPRING PIN	5x30	2
3	33-4024	GEAR	M1.5x18T	1
4	33-4010	PINION SHAFT	M1.5x13T	1
5	GB79-85	SET SCREW	M6x16	1
6	33-4049	SLEEVE		1
7	GB70-85	SOCKET HEAD CAP SCREW	M6x12	1
8	32-06240	WASHER		1
9	32-06231	GEAR		1
10	32-06232	IDLE SHAFT		1
11	GB70-85	SOCKET HEAD CAP SCREW	M5x12	2
12	GB1255-76	O-RING		2
13	33-4026	SHAFT		1
13A	GB1095	KEY	A5X5X12	1
14	32-06429	WORM GEAR		1
15	33-4028	WASHER		1
16	GB5783-86	CAP SCREW	M6x12	1
17	33-4038	INTERLOCK PIECE		1
18	GB6170-86	PAN HEAD SCREW	M6x20	1
19	GB77-85	SOCKET HEAD SET SCREW	M6x12	1
20	GB5783-86	HEXAGON HEAD SCREW	M5x20	3
21	33-4036	GIB		1
22	GB5783-86	HEXAGON HEAD SCREW	M6x10	2
23	GB77-85	SOCKET HEAD SET SCREW	M6x35	1
24	GB6170-85	HEX NUT	M6	1
24A	GB6170-85	HEX NUT	M8	1
26	33-4035	HALF NUT BASE		1
27	33-4035 1/2	HALF NUT		1
28	GB119-86	PIN	8x16	2
29	32-06228	WORM		1
29A	GB1095	KEY	5X5X36	1
29B	GB819-85	SCREW	M3X6	1
30	32-06225	CAM SHAFT		1
31	GB80-85	SOCKET HEAD SET SCREW	M5x16	3
32	GB41-86	HEXAGON NUT	M5	3
33	33-4040A	DIAL INDICATOR		1
34	33-4039A	THREAD DIAL BODY		1
36	GB70-85	SOCKET HEAD CAP SCREW	M8x50	1
39	GB95-85	WASHER	8	1
40	GB41-86	HEXAGON NUT	M8x50	1
41	33-4043	HELICAL GEAR		1
42	32-06237	SPACER		3
43	33-4042	HELICAL GEAR		1
44	33-4041	HELICAL GEAR		1
45	GB827-86	BUTTON HEAD RIVER	2x5	5
48	Q/ZG285.3	DRAIN PLUG	1/8	1
49	33-4050	HALF NUT INDICATOR		1

**NOTE: SOME INDIVIDUAL PARTS MAY ONLY BE AVAILABLE AS AN ASSEMBLY**

## APRON ASSEMBLY - PARTS LIST CONT.

INDEX NO	PART NO	DESCRIPTION	SIZE	QTY
50	GB1160-89	OIL SIGHT GLASS	A20	1
51	GB879-86	SPRING PIN	5x35	1
52	GB2089-80	COMPRESSION SPRING		1
53	GB308-77	STEEL BALL	Ø5	1
53A	GB308-77	STEEL BALL	Ø6	1
54	33-4027	PLUG		1
55	GB879-86	SPRING PIN	3x25	1
56	GB119-85	PIN	C5x25	3
57	GB77-85	SOCKET HEAD SET SCREW	M6x6	1
57A	GB77-85	SOCKET HEAD SET SCREW	M8x6	1
58	33-4033	LEVER HANDLE		1
59A	33-4034	LEVER		1
62	33-4002	FRONT COVER		1
63	33-4047	FEED DIRECTION INDICATOR		1
65	33-4020	CAM SHAFT		1
66	33-4022	CHANGE LEVER		1
67	GB2089-80	COMPRESSION SPRING		1
68	33-4019	BRACKET		1
69	GB70-85	SOCKET HEAD CAP SCREW	M6x35	3
70	CL6132-06-02	PLUG		1
71	33-4013	SHIFTING SHAFT		1
72	GB70-85	SOCKET HEAD CAP SCREW	M6x16	4
73	33-4016	CLUTCH GEAR		1
74	33-4015	CLUTCH GEAR		1
75	33-4014	CLUTCH GEAR		1
76	33-4011	PLUG		1
77	GB1155-79	BALL CAP		3
78	33-4008	BOLT		1
79	33-4009	HANDLE		1
80	GB818-85	CROSS RECESSED HEAD SCREW	M6x15	1
81	33-4007	WASHER		1
82	33-4005	HANDLE WHEEL		1
83	33-4006	DIAL		1
84	GB70-85	SOCKET HEAD CAP SCREW	M5x25	3
85	33-4004	BRACKET		1
87	GB1096-79	DOUBLE ROUND HEAD KEY	5x5x20	1
88	33-4003	GEAR SHAFT		1

**NOTE: SOME INDIVIDUAL PARTS MAY ONLY BE AVAILABLE AS AN ASSEMBLY**

**SADDLE & CROSS SLIDE - DIAGRAM**

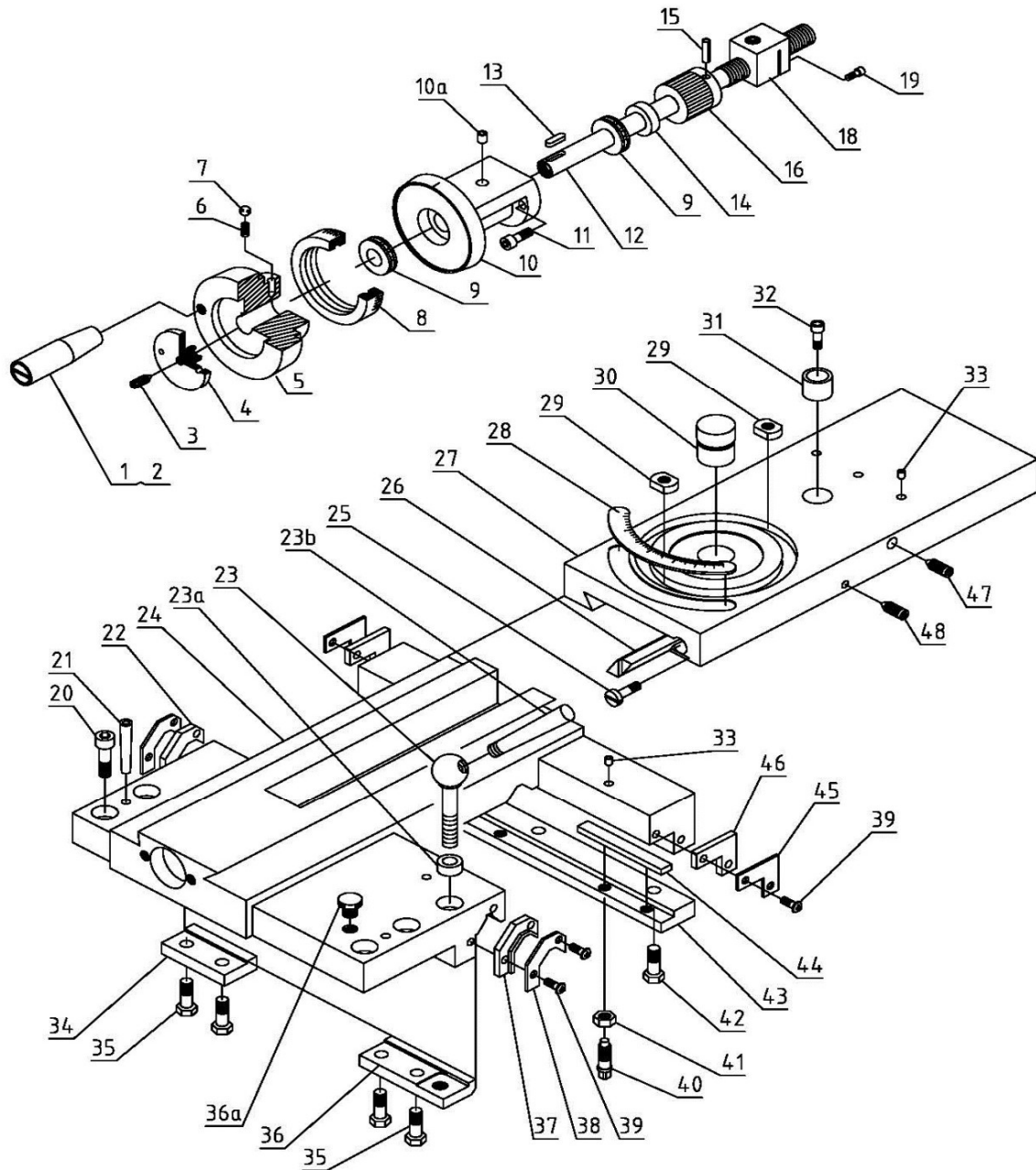

**SADDLE & CROSS SLIDE - PARTS LIST**

INDEX NO	PART NO	DESCRIPTION	SIZE	QTY
1	D330A-81202	COLLAR		1
2	D330A-81203-2	SCREW	M10	1
3	GB78	SCREW	M6×25	1
4	D330B-51207G-1	ADJUSTING SCREW		1
5	D330B-51207G	HANDLE WHEEL		1
6	GB2089	SPRING	Y1-5×1×12	1

**NOTE: SOME INDIVIDUAL PARTS MAY ONLY BE AVAILABLE AS AN ASSEMBLY**

### SADDLE & CROSS SLIDE - PARTS LIST CONT...

INDEX NO	PART NO	DESCRIPTION	SIZE	QTY
7	GB308	STEEL BALL	5	1
8	D330B-51208G	INDEX RING		1
9	GB301	THRUST BALL BEARING	51102	2
10	D330B-51106G	BRACKET		1
10A	GB1155	OIL CUP	8	1
11	GB70	SOCKET HEAD SCREW	M6x20	2
12	D330B-51206G	CROSS LEADSCREW	METRIC OR INCH	1
13	GB1096	KEY	5x8	1
14	D330A-51201	SPACE WASHER		1
15	GB879	SPRING PIN	4x25	1
16	D330C-51202C	GEAR		1
18	D330B-51401G	COPPER NUT		1
19	GB70	SOCKET HEAD SCREW	M6x16	1
20	GB70	SOCKET HEAD SCREW	M10x30	4
21	GB118	TAPER PIN	6x45	2
22	D330A-51301	LEFT RUBBER WIPER		1
23	D330A-S1001	LOCK HANDLE SCREW	1	1 (OPTIONAL)
23A	D330A-S1003	BUSHING		1 (OPTIONAL)
23B	D330A-S1002	LOCK HANDLE		1 (OPTIONAL)
24	D330B-51101G	SADDLE CASTING		1
25	D330A-51214	ADJUSTING SCREW		2
26	D330B-51212G	WEDGE		1
27	D330B-51102G	CROSS SLIDE		1
28		STAFF GUAGE		1
29	D330B-51203G	TAILOR-MADE NUT		2
30	D330B-51219G	SLIDE AXIS	4x80	1
31	D330B-51201G	WASHER		1
32	GB70	SOCKET HEAD SCREW	M8x16	1
33	GB1155	OIL CUP	6	5
34	D330A-51103	FRONT STRIP		1
35	GB5781	HEXAGON(AL) HEAD TAP BOLT	M8x20	4
36A	D330A-51215	SCREW PLUG		1
36	D330A-51105	STRIP		1
37	D330A-51302	RIGHT RUBBER WIPER		1
38	D330A-51205	PLATE		2
39	GB818	CUP HEAD SCREW	M5x12	8
40	GB83	COACH BOLT	M8x25	4
41	GB6170	HEXAGON HEAD NUT	M8	4
42	GB5781	HEXAGON(AL) HEAD TAP BOLT	M8x25	3
43	D330A-51104	BACK STRIP		1
44	D330A-51216	WEDGE		2
45	D330A-51204	PLATE		2
46	D330A-51303	BACK RUBBER WIPER		2
47	GB78	SCREW	M8x16	1
48	GB78	SCREW	M6x12	1

**NOTE: SOME INDIVIDUAL PARTS MAY ONLY BE AVAILABLE AS AN ASSEMBLY**

**TOOL POST ASSEMBLY - DIAGRAM**

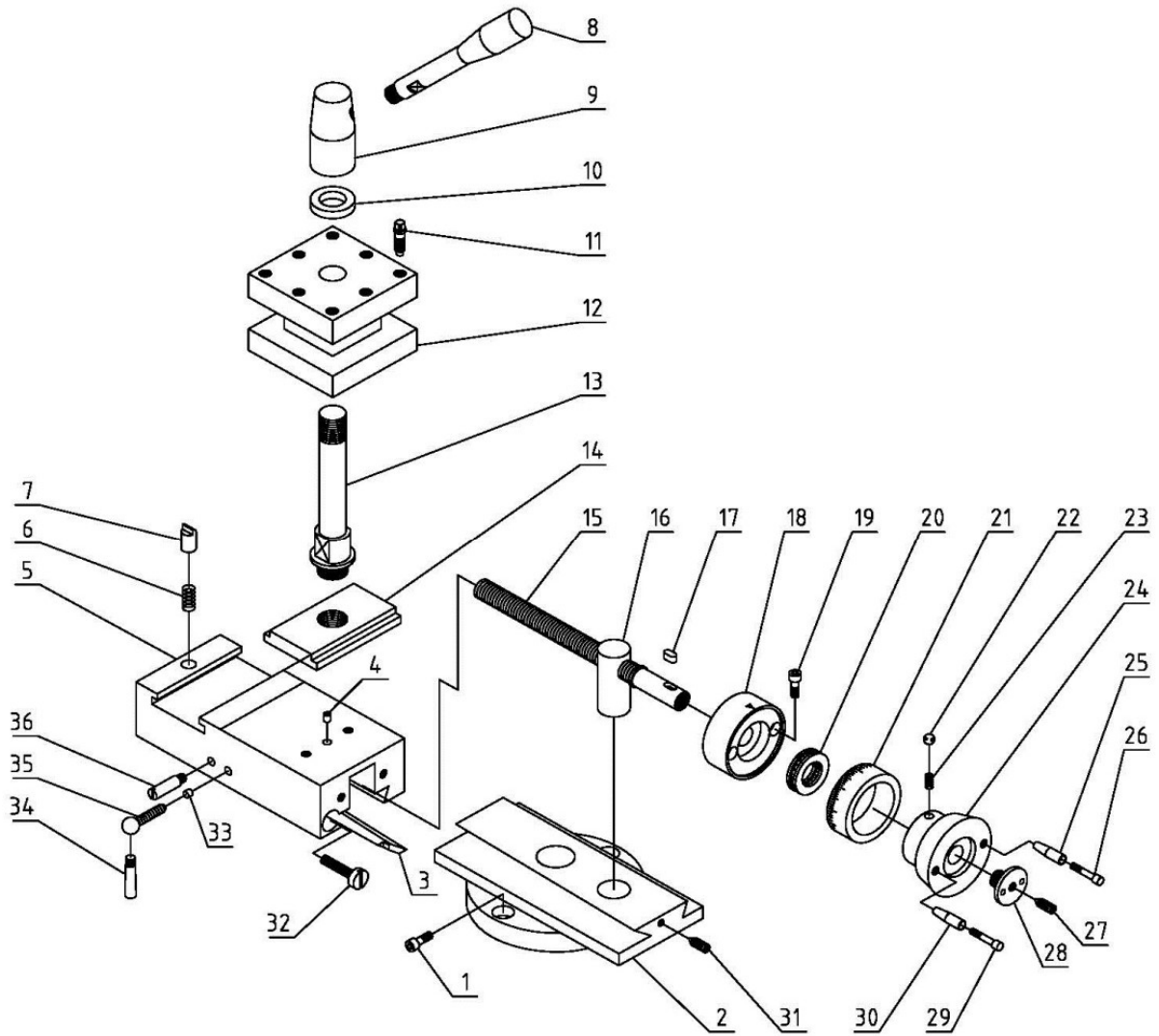

## TOOL POST ASSEMBLY - PARTS LIST

INDEX NO	PART NO	DESCRIPTION	SIZE	QTY
1	GB70	SOCKET HEAD SCREW	M8x16	2
2		SWIVEL SLIDE		1
3		WEDGE		1
4	GB1155	OIL CUP	6	3
5		COMPOUND REST BODY		1
6	GB2089	SPRING	Y1-8x1x11	1
7		WIPER		1
8		HANDLE		1
9		HANDLE BASE		1
10		WASHER		1
11	GB83	COACH BOLT	M10x50	8
12		TOOL POST		1
13		SHAFT		1
14		PLATE		1
15		LEADSCREW	METRIC OR INCH	1
16		NUT		1
17	GB1096	KEY	4x14	1
18		BRACKET		1
19	GB70	SOCKET HEAD SCREW	M6x16	2
20	GB301	THRUST BALL BEARING	51103	1
21		INDEX RING		1
22	GB2089	SPRING	Y1-5x1x12	1
23	GB308	STEEL BALL	5	1
24		HANDLE WHEEL		1
25		COLLAR		1
26		BOLT		1
27	GB78	SCREW	M6x25	1
28		ADJUSTING SCREW		1
29		BOLT		1
30		COLLAR		1
31	GB78	SCREW	M6x8	1
32		ADJUSTING BOLT		1
33		LOCKING PIN	4X8	1
34	D330A-S2002	LOCK HANDLE		1
35	D330B-S3001	LOCK HANDLE SCREW		1
36	D330A-S2003	THREADED RETAINING PIN		1

**NOTE: SOME INDIVIDUAL PARTS MAY ONLY BE AVAILABLE AS AN ASSEMBLY**

**TAILSTOCK ASSEMBLY - DIAGRAM**

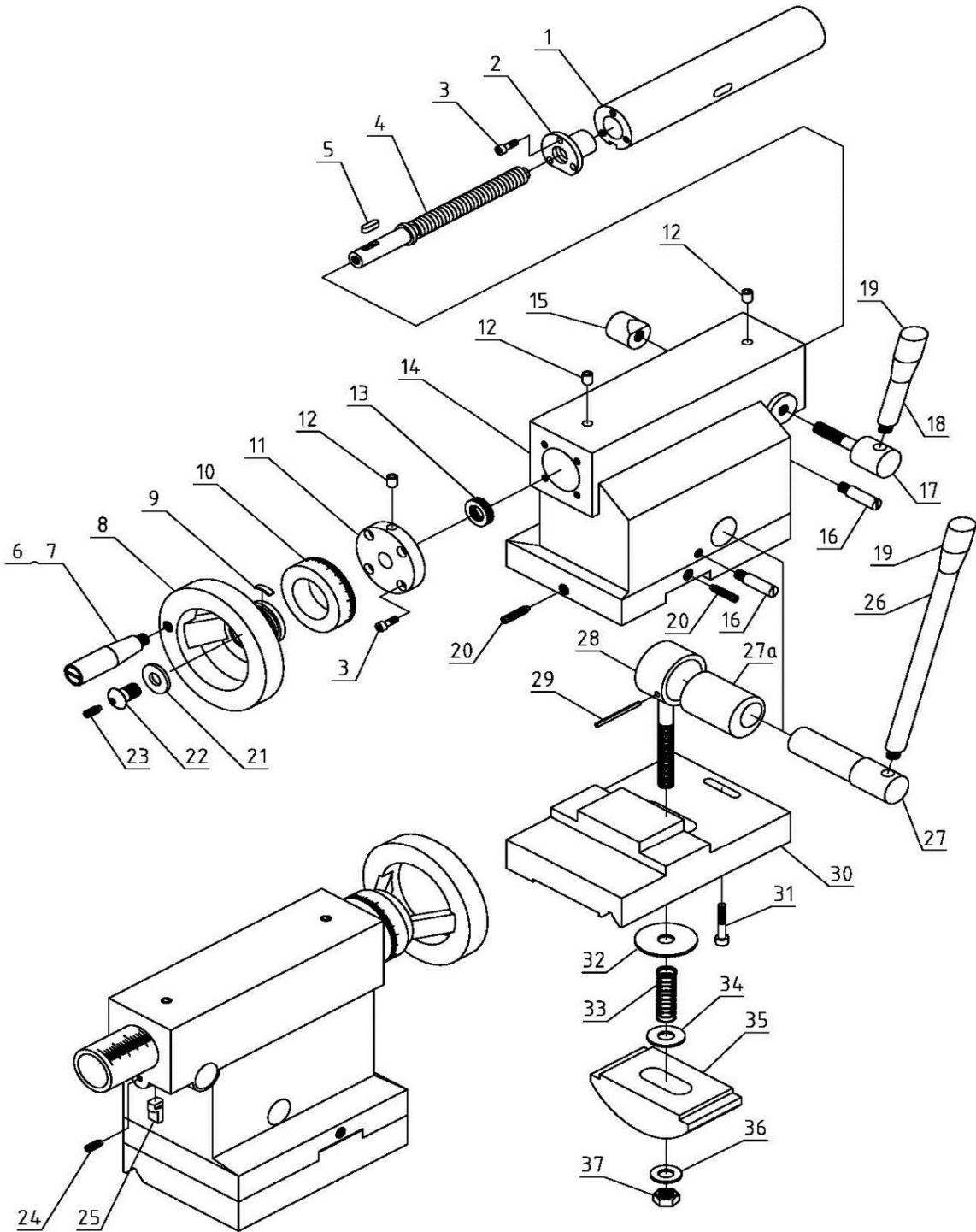

## TAILSTOCK ASSEMBLY - PARTS LIST

INDEX NO	PART NO	DESCRIPTION	SIZE	QTY
1		SLEEVE		1
2		COPPER NUT		1
3	GB70	SOCKET HEAD SCREW	M4x12	3
4		LEADSCREW		1
5	GB1096	KEY	4x15	1
6	D330A-81202	COLLAR		1
7	D330A-81203-1	BOLT	M8	1
8		HANDLE WHEEL		1
9		SPRING REED		1
10	D330A-6010	INDEX RING		1
11		END COVER		1
12	GB1155	OIL CUP	8	3
13	GB301	THRUST BALL BEARING	51102	1
14		TAILSTOCK CASTING		1
15		LOCK BLOCK		1
16		PIN		2
17		SHAFT		1
18		HANDLE		1
19	JB1342	COVER	M10X50	2
20	GB79	SCREW	M10x50	3
21	GB97.1	WASHER	12	1
22		ADJUSTING SCREW		1
23	GB78	SCREW	M6x25	1
24	GB79	SCREW	M6x8	1
25		PIN		1
26		HANDLE		1
27		ECCENTRICITY SHAFT		1
27A				1
28		DRAW-IN BOLT		1
29	GB879	SPRING PIN	4x50	1
30		BASE		1
31	GB70	SOCKET HEAD SCREW	M6X40	1
32	D330A-6042	TAILOR-MADE WASHER		1
33		SPRING		1
34	D330A-6043	TAILOR-MADE WASHER		1
35		CLAMP PLATE		1
36	GB97.1	WASHER	16	1
37	GB6170	HEXAGON NUT	M16	1

**NOTE: SOME INDIVIDUAL PARTS MAY ONLY BE AVAILABLE AS AN ASSEMBLY**

**STEADY & FOLLOW REST - DIAGRAM**

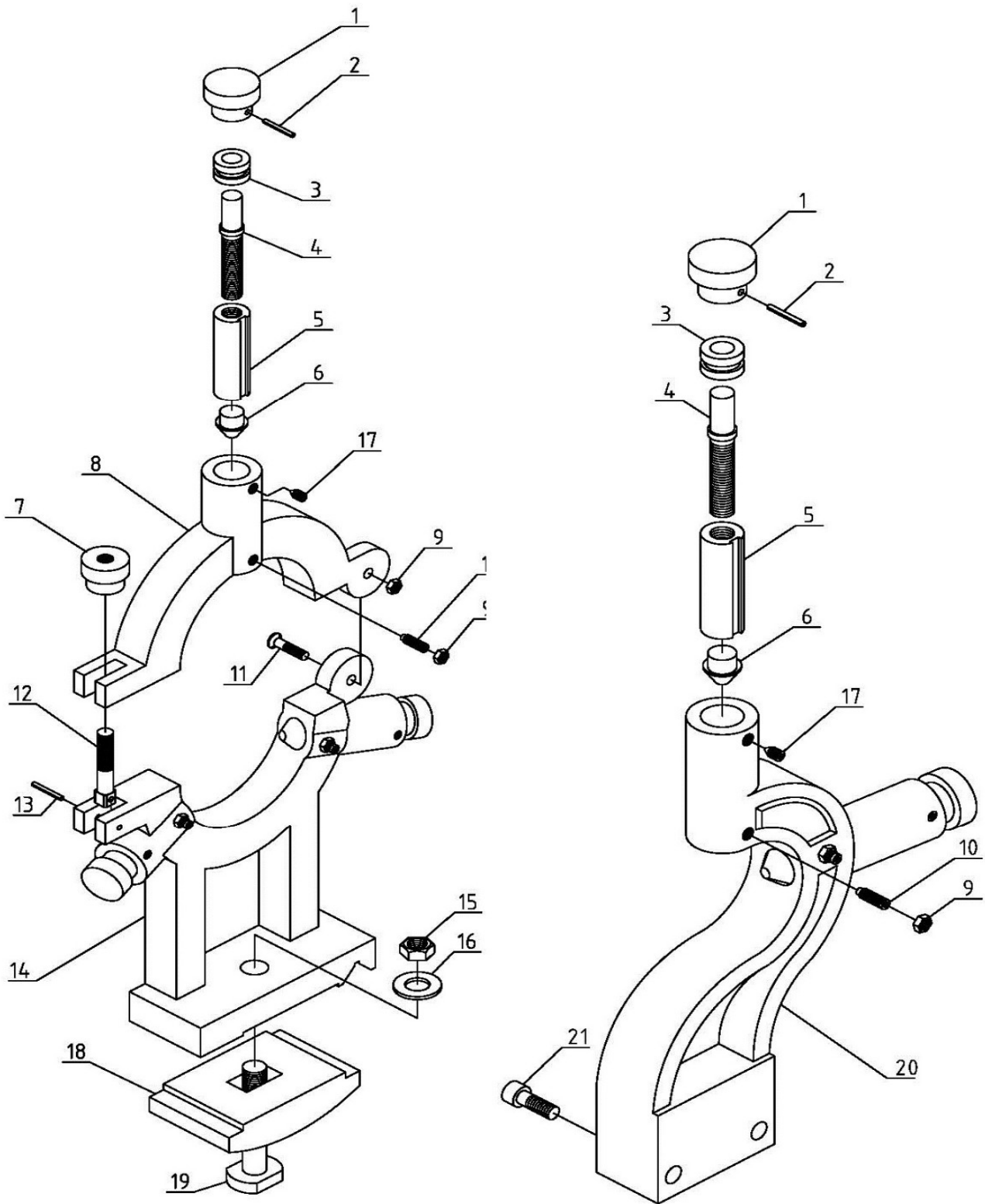

### STEADY & FOLLOW REST - PARTS LIST

INDEX NO	PART NO	DESCRIPTION	SIZE	QTY
1	JB1360-76	KNOB	M32X8	3
2	GB119-86	PIN	3X18	3
3	3210203	COLLAR		3
4	32-10204	SCREW		3
5	32-10201	COLLAR		3
6	32-10401	CLAPPING HEAD		3
7	32-10205	NUT		1
8	32-10101	UPSIDE OF CENTER REST		1
9	GB6170-86	NUT	M6	4
10	GB79-85	SCREW	M6X18	3
11	GB65-85	SCREW	M6X30	1
12	32-10206	SCREW		1
13	GB87986	PIN	5X24	1
14	32-10102	DOWNSIDE OF CENTER REST		1
15	GB6170-86	NUT	M12	1
16	GB97.1-86	WASHER	12	1
17	GB78-85	SCREW	M6X6	3
18	32-10103	CLAMP		1
19	GB37-85	SCREW	M12X65	1
20	3210104	FOLLOW REST		1
21	GB70-85	SCREW	M8X46	2

**NOTE: SOME INDIVIDUAL PARTS MAY ONLY BE AVAILABLE AS AN ASSEMBLY**

**COOLANT & WORK LIGHT - DIAGRAM**

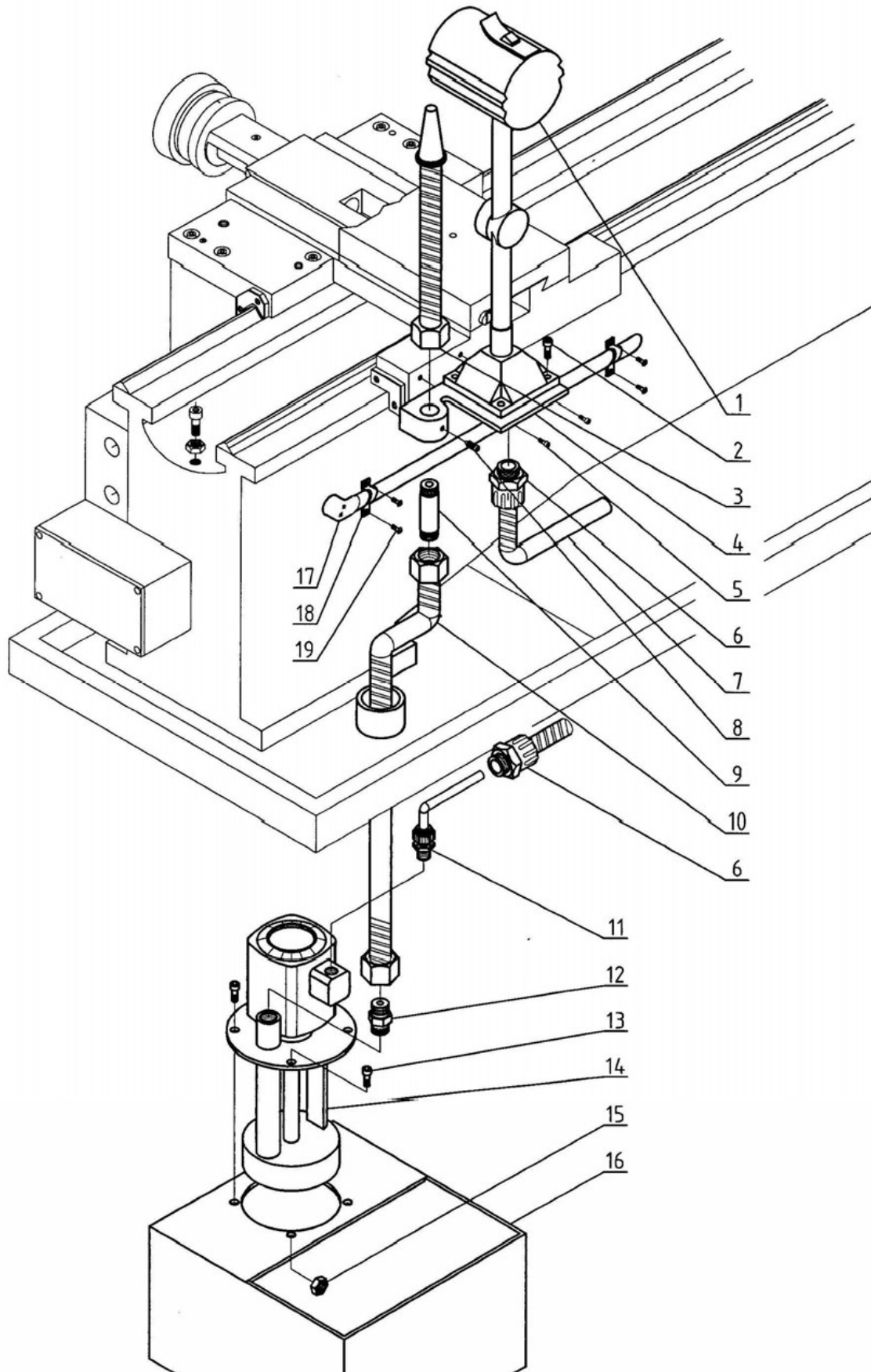

## COOLANT & WORK LIGHT - PARTS LIST

INDEX NO	PART NO	DESCRIPTION	SIZE	QTY
1	32-15201	WORK LIGHT		1
2	GB70	SOCKET HEAD SCREW	M5x12	4
3		LIQUID NOZZLE		1
4	D330A-71206-2	BRACKET		1
5	GB70	SOCKET HEAD SCREW	M6x16	2
6		LOCK CONNECTING	M20x1.5	2
7		PLASTIC TUBE		1
8	GB78	SCREW	M6x12	1
9	D330A-92202	PIPE		1
10		METAL COOLING TUBE		1
11		LOCK CONNECTING	M12x1	1
12	D330A-92203	CONNECTING		1
13	GB70	SOCKET HEAD SCREW	M5x12	4
14	AB-12	PUMP		1
15	GB6170	HEXAGON NUT	M5	2
16	D330B-14401	WATER TANK		1
17		ELBOW CONNECTING		1
18		HEMICYCLE CLIP	C-16	2
19	GB818	SCREW	M5x10	4

**NOTE: SOME INDIVIDUAL PARTS MAY ONLY BE AVAILABLE AS AN ASSEMBLY**

**ELECTRIC ASSEMBLY 1/2 - DIAGRAM**

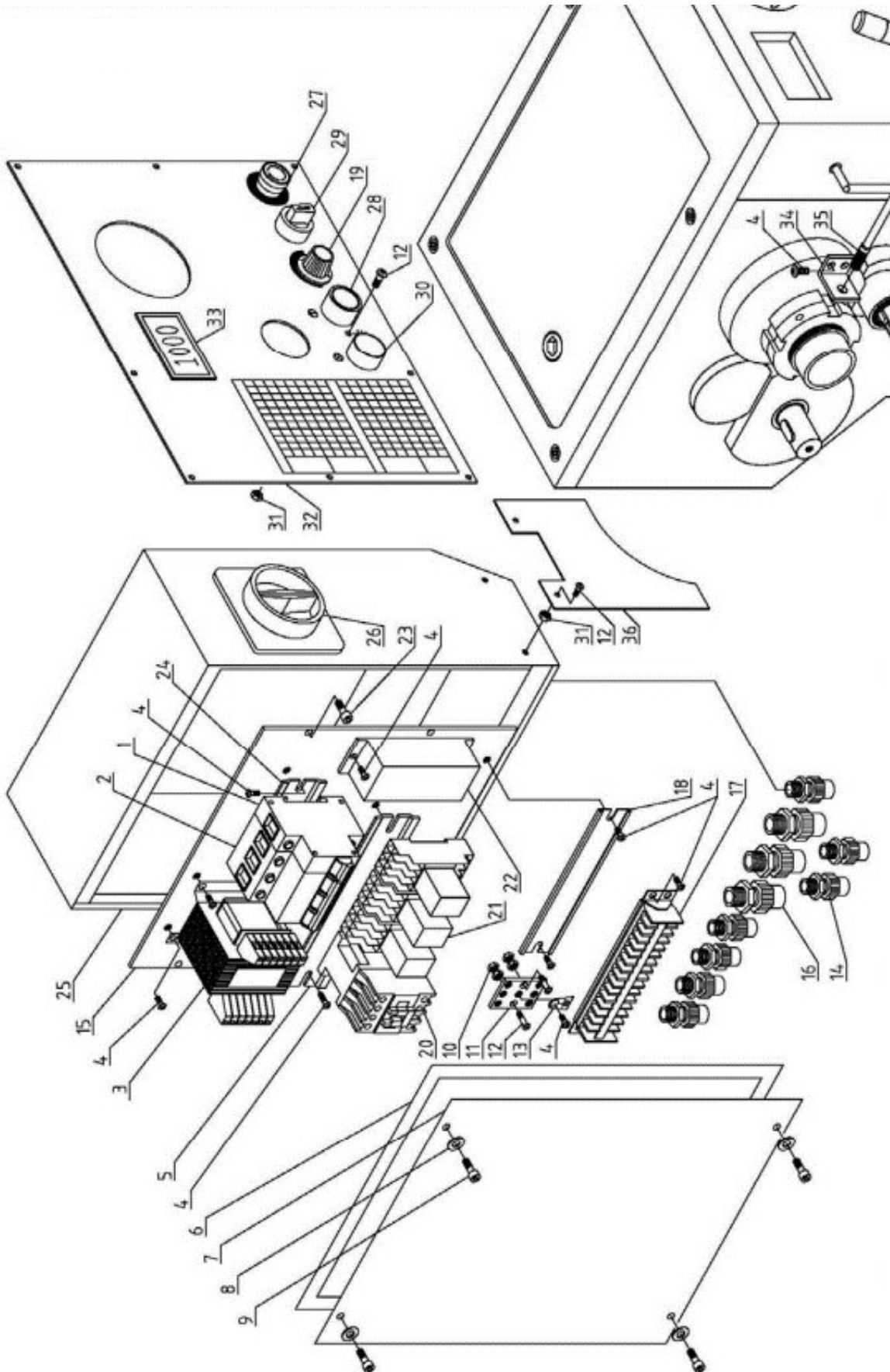

## ELECTRIC ASSEMBLY 1/2 - PARTS LIST

INDEX NO	PART NO	DESCRIPTION	SIZE	QTY
1		PROTECTIVE CIRCUIT BREAKER	DZ47-63C3 1P	1
2		PROTECTIVE CIRCUIT BREAKER	DZ47-63C6 3P	1
3		TRANSFORMER	JBK5-100VA-TH	1
4	GB818	SCREW	M4X6	17
5		FIXING RAIL CLIP		1
6		RUBBER CUSHING		1
7	D330B-14102	COVER		1
8	GB97.1	WASHER	4	4
9	GB70	HEX SOCKET CAP SCREW	M4X10	4
10	GB6170	NUT	M5	4
11	D330A-71401	SHEET COPPER		1
12	GB818	SCREW	M4X12	5
13		EARTH SIGN PLATE		1
14		LOCKER CONNECTING	M16X1.5	7
15	D330B-14103	BASE		1
16		LOCKER CONNECTING	M20X1.5	3
17		JUNCTION BOX	20 SEAT	1
18		FIXING RAIL CLIP		1
19		ADJUSTABLE RESISTOR		1
20		AC CONTACTOR	3TB41	1
21		CONTACTOR RELAY	HH54P	3
22		SOURCE	5V	1
23	GB70	HEX SOCKET CAP SCREW	M6X12	4
24		FIXING RAIL CLIP		1
25	D330V-14101A	ELECTRIC BOX		1
26		POWER SWITCH	LW26-20	1
27		EMERGENCY PRESS BUTTON		1
28		JOG BUTTON		1
29		BUTTON SWITCH	LAY3-11/2	1
30		RESET BUTTON		1
31	GB6170	NUT	M4	3
32		NAME PLATE		1
33		SPEED DISPLAY		1
34	D330DV-21255	ANGLE IRON		1
35		SPEED SIGNAL LINE		1
36	D330B-14220A	SAFETY GUARD		1

**NOTE: SOME INDIVIDUAL PARTS MAY ONLY BE AVAILABLE AS AN ASSEMBLY**

**ELECTRIC ASSEMBLY 2/2 - DIAGRAM**

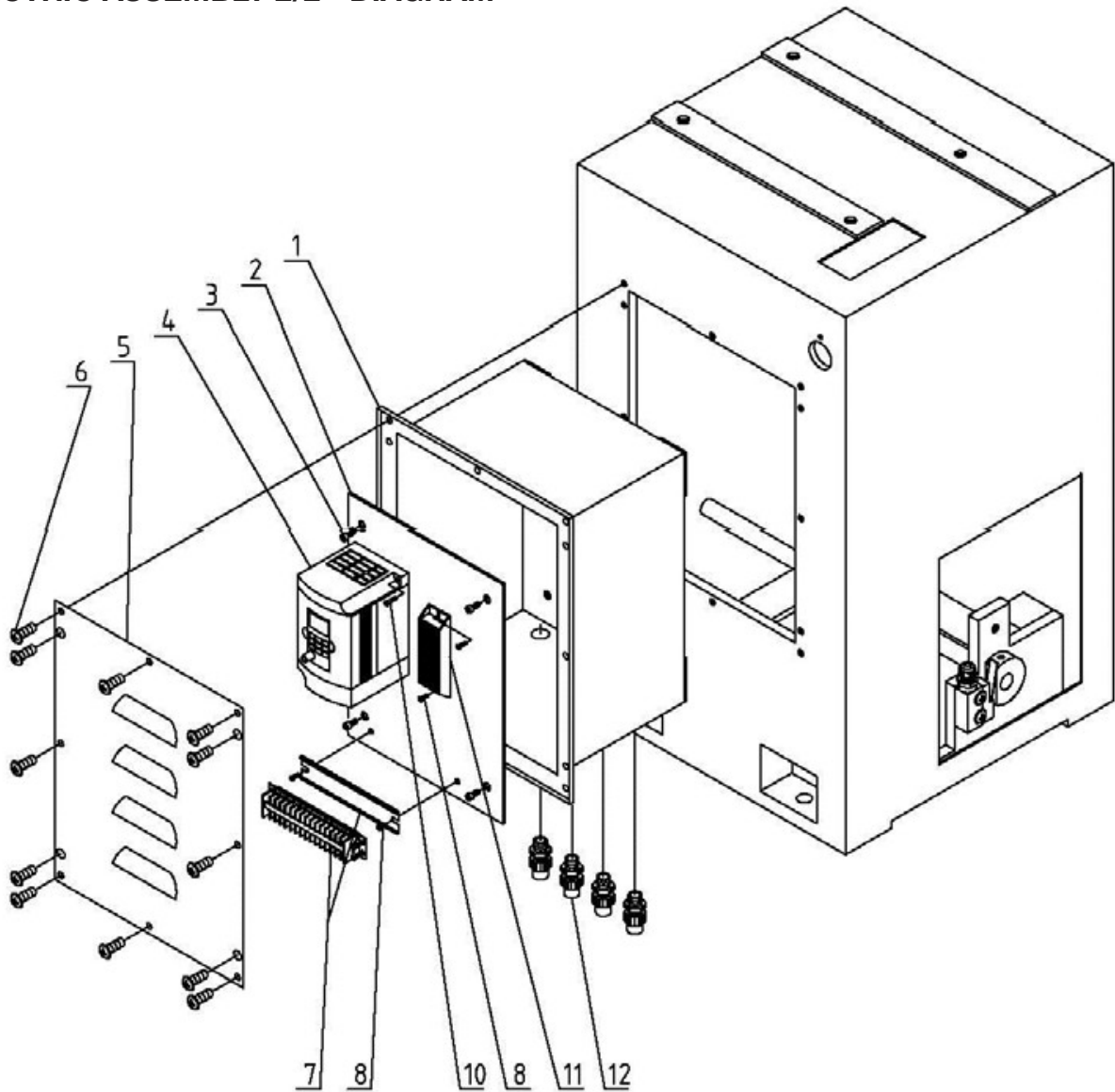

**ELECTRIC ASSEMBLY 2/2 - PARTS LIST**

INDEX NO	PART NO	DESCRIPTION	SIZE	QTY
1	D330DV-14101	ELECTRIC BOX		1
2	D330DV-14103	CIRCUITRY ASSEMBLY PLATE		1
3	GB70	HEX SOCKET CAP SCREW	M5X10	4
4		INVERTER	MS300	1
5	D330DV-14102	COVER		1
6	GB818	SCREW	M6X10	12
7		JUNCTION BOX	20 SEAT	1
8	GB818	SCREW	M4X6	4
10	GB818	SCREW	M4X12	2
11		BRAKING RESISTOR		1
12		LOCKER CONNECTING	M20X1.5	4

**NOTE: SOME INDIVIDUAL PARTS MAY ONLY BE AVAILABLE AS AN ASSEMBLY**

**TOOL & TOOL BOX - DIAGRAM**

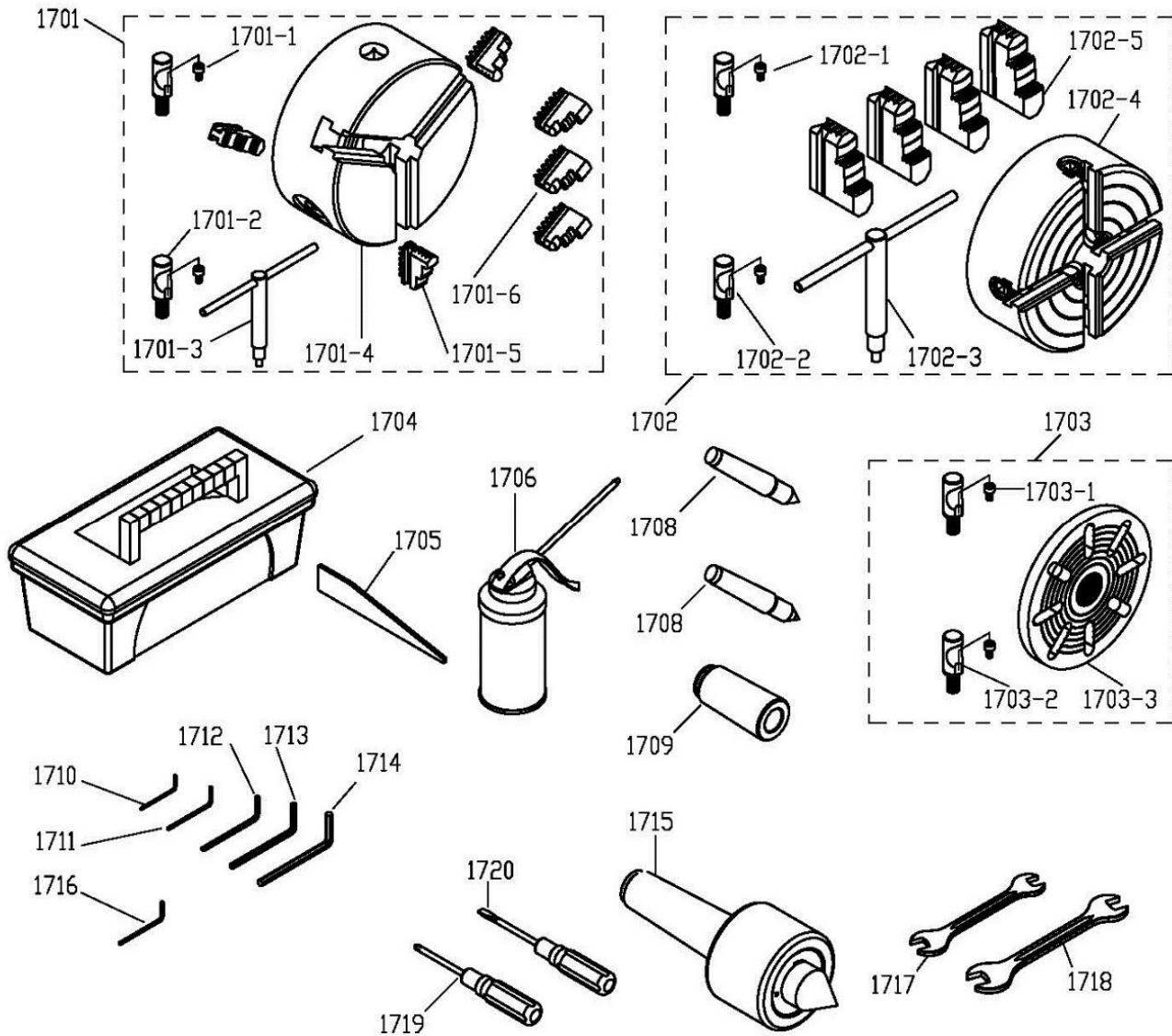

**TOOL & TOOL BOX - PARTS LIST**

INDEX NO	PART NO	DESCRIPTION	SIZE	QTY
1701		3-JAW CHUCK ASSEMBLY	200MM-D5	1
1701-1	GB/T70	HEX SOCKET CAP SCREW	M6X20	6
1701-2	D330D-81201	CAMLOCK STUD		6
1701-3		3-JAW CHUCK KEY		1
1701-4		3-JAW CHUCK BODY		1
1701-5		INTERNAL JAWS 3PCS SET		1
1701-6		REVERSE JAWS 3PCS SET		1
1702		4-JAW CHUCK ASSEMBLY	200MM-D5	1 (OPTIONAL)
1702-1	GB/T70	HEX SOCKET CAP SCREW	M6X20	6
1702-2	D330D-81201	CAMLOCK STUD		6
1702-3		4-JAW CHUCK KEY		1

**NOTE: SOME INDIVIDUAL PARTS MAY ONLY BE AVAILABLE AS AN ASSEMBLY**

### TOOL & TOOL BOX - PARTS LIST CONT...

INDEX NO	PART NO	DESCRIPTION	SIZE	QTY
1702-4		4-JAW CHUCK BODY		1
1702-5		JAWS 4PCS SET		1
1703		FACE PLAT ASSEMBLY	250MM	1 (OPTIONAL)
1703-1	GB/T70	HEX SOCKET CAP SCREW	M6X20	6
1703-2	D330D-81201	CAMLOCK STUD		6
1703-3	330D-81103	FACE PLAT BODY		1
1704	JD1440B2-1704	TOOL BOX		1
1705	D330B-F5001	DRIFT KEY		1 (OPTIONAL)
1706		OIL GUN		1
1708		DEAD CENTERS MT4	MT4	2
1709		TAPERED REDUCING SLEEVE	MT6-MT4	1
1710		HEX WRENCH 2MM	2MM	1
1711		HEX WRENCH 3MM	3MM	1
1712		HEX WRENCH 4MM	4MM	1
1713		HEX WRENCH 5MM	5MM	1
1714		HEX WRENCH 6MM	6MM	1
1715		LIVE CENTERS MT4	MT4	1 (OPTIONAL)
1716		HEX WRENCH 6MM	3/16"	1
1717	JD1440B2-1717	OPEN END WRENCHES	16-18MM	1
1718	JD1440B2-1718	OPEN END WRENCHES	17-19MM	1
1719	JD1440B2-1719	CROSS POINT SCREWDRIVER	3"	1
1720	JD1440B2-1720	FLAT BLADE SCREWDRIVER	3"	1

**NOTE: SOME INDIVIDUAL PARTS MAY ONLY BE AVAILABLE AS AN ASSEMBLY**

**CHUCK SAFETY GUARD - DIAGRAM**

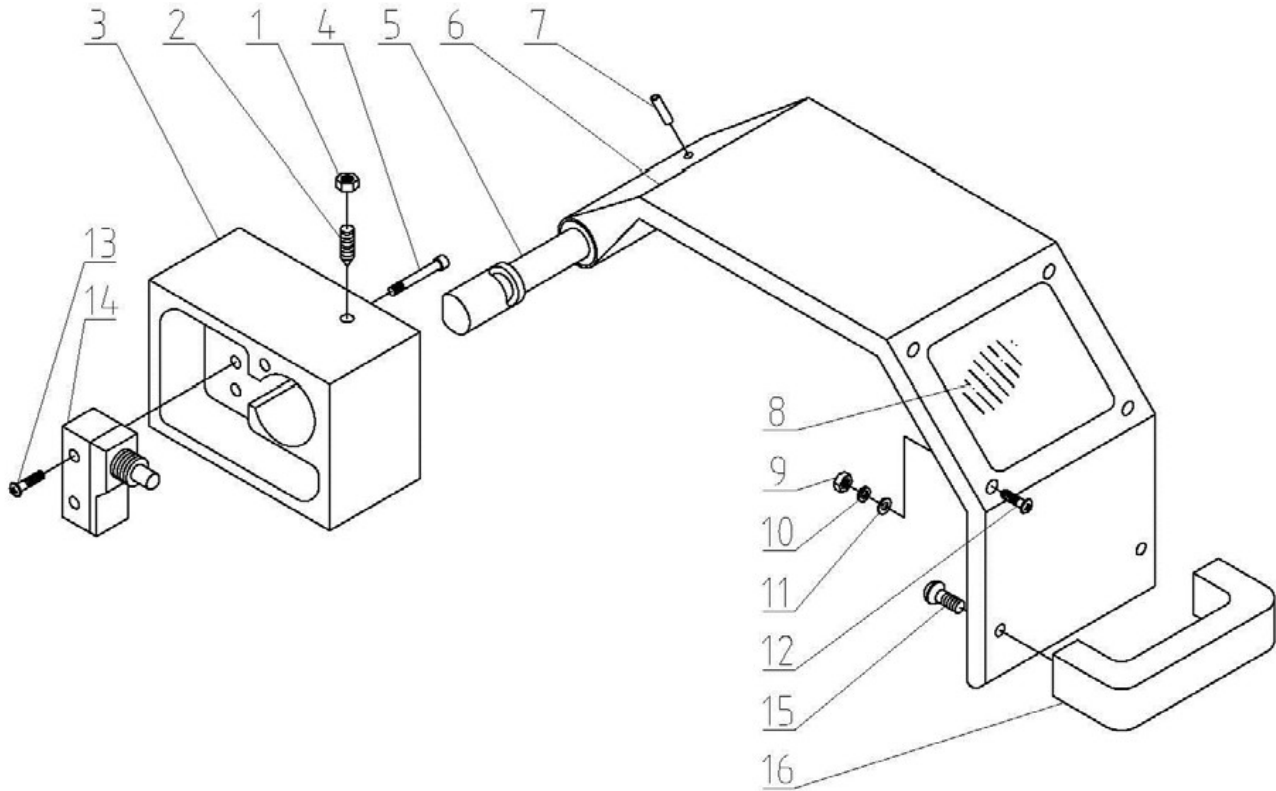

**CHUCK SAFETY GUARD - PARTS LIST**

INDEX NO	PART NO	DESCRIPTION	SIZE	QTY
1	GB6170	NUT	M4	1
2	GB79	SCREW	M6x16	1
3	D330A-71101	BOX		1
4	GB70	HEX SOCKET CAP SCREW	M6x45	2
5	D330A-71203	SHAFT		1
6	D330A-71204A-1	CHUCK GUARD		1
7	GB879	PIN	4x25	1
8	D330A-71402	ACRYLIC PLATE		1
9	GB6175	NUT	M3	4
10	GB93	WASHER	3	4
11	GB97.1	WASHER	3	4
12	GB818	SCREW	M3X12	4
13	GB818	SCREW	M4X25	2
14		SWITCH	LXW5-11M	1
15	GB818	SCREW	M6X8	2
16		HANDLE		1

**NOTE: SOME INDIVIDUAL PARTS MAY ONLY BE AVAILABLE AS AN ASSEMBLY**

**LEADSCREW GUARD - DIAGRAM**

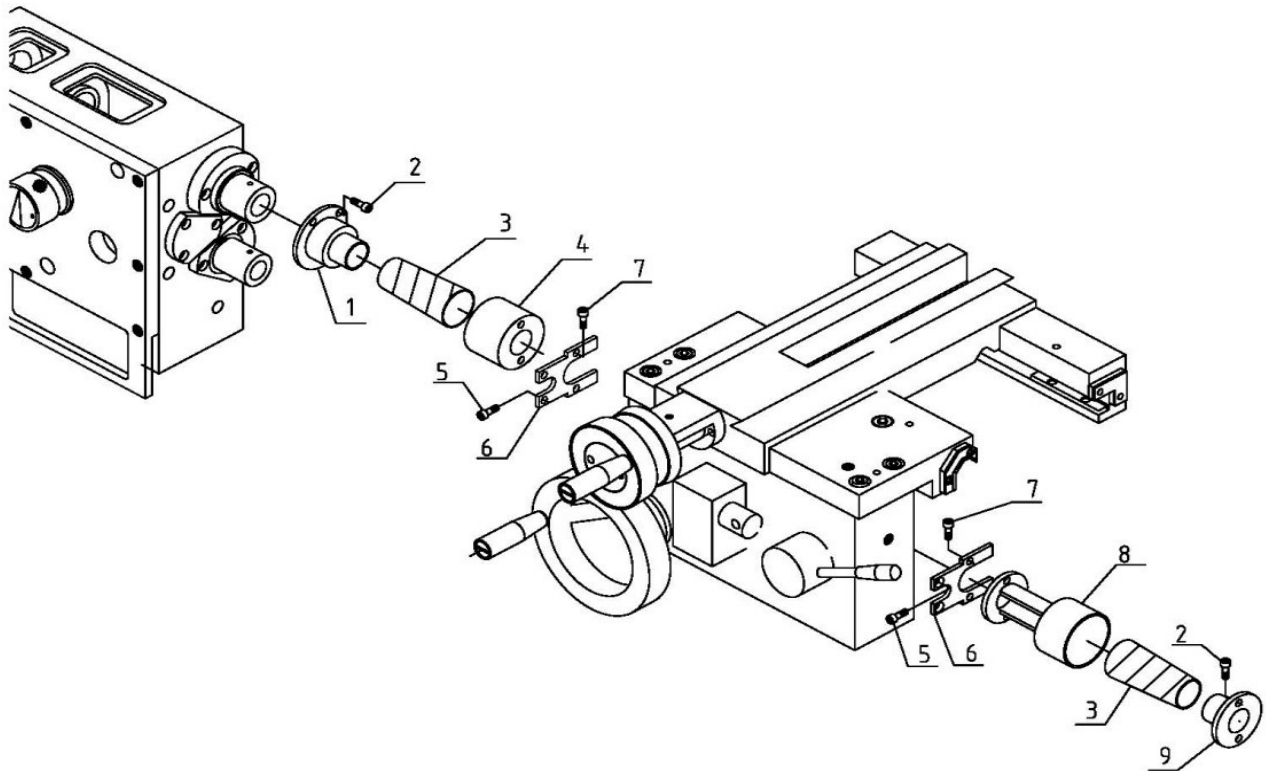

**LEADSCREW GUARD - PARTS LIST**

INDEX NO	PART NO	DESCRIPTION	SIZE	QTY
1	D330B-1030G	BRACKET		1
2	GB70	SOCKET HEAD SCREW	M5x10	4
3	D330-F3001	SPRING COVER		2
4	D330A-1034	LEFT BRACKET		1
5	GB70	SOCKET HEAD SCREW	M6x12	4
6	D330A-1032	BRACKET PLATE		2
7	GB70	SOCKET HEAD SCREW	M4x10	4
8	D330B-1029G	RIGHT BRACKET		1
9	D330A-1031	BRACKET		1

**NOTE: SOME INDIVIDUAL PARTS MAY ONLY BE AVAILABLE AS AN ASSEMBLY**

**CLUTCH FOR FEED ROAD - DIAGRAM**

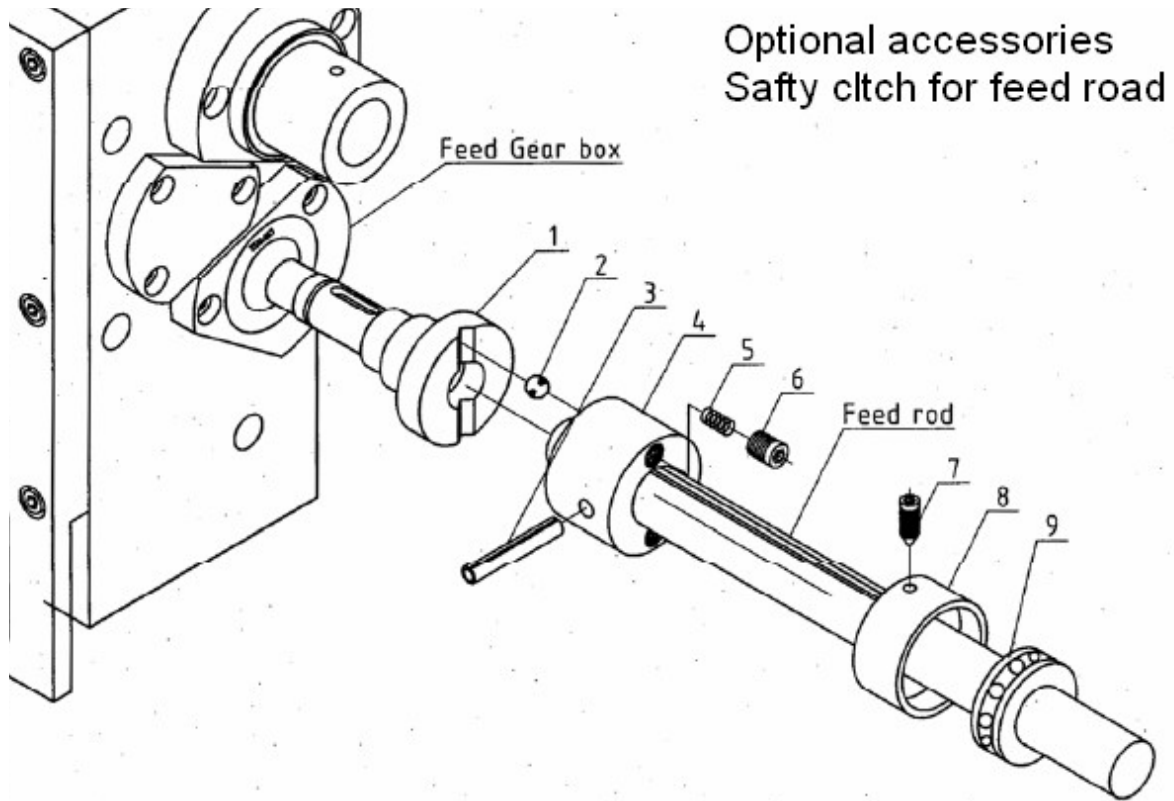

**CLUTCH FOR FEED ROAD - PARTS LIST**

INDEX NO	PART NO	DESCRIPTION	SIZE	QTY
1	D330B-36101-01	SHAFT		1
2	GB308	STEEL BALL	6	4
3	GB879	SPRING PIN	4x42	2
4	D330B-36101-02	CLUTCH		1
5	GB1358	SPRING	Y1-6x1x25	4
6	GB77	SCREW	M8x8	4
7	GB78	SCREW	M6x10	1
8	D330B-CS004	COVER		1
9	GB301	BEARING	51104	1

**NOTE: SOME INDIVIDUAL PARTS MAY ONLY BE AVAILABLE AS AN ASSEMBLY**

**QUICK CHANGE TOOLPOST (OPTIONAL) - DIAGRAM**

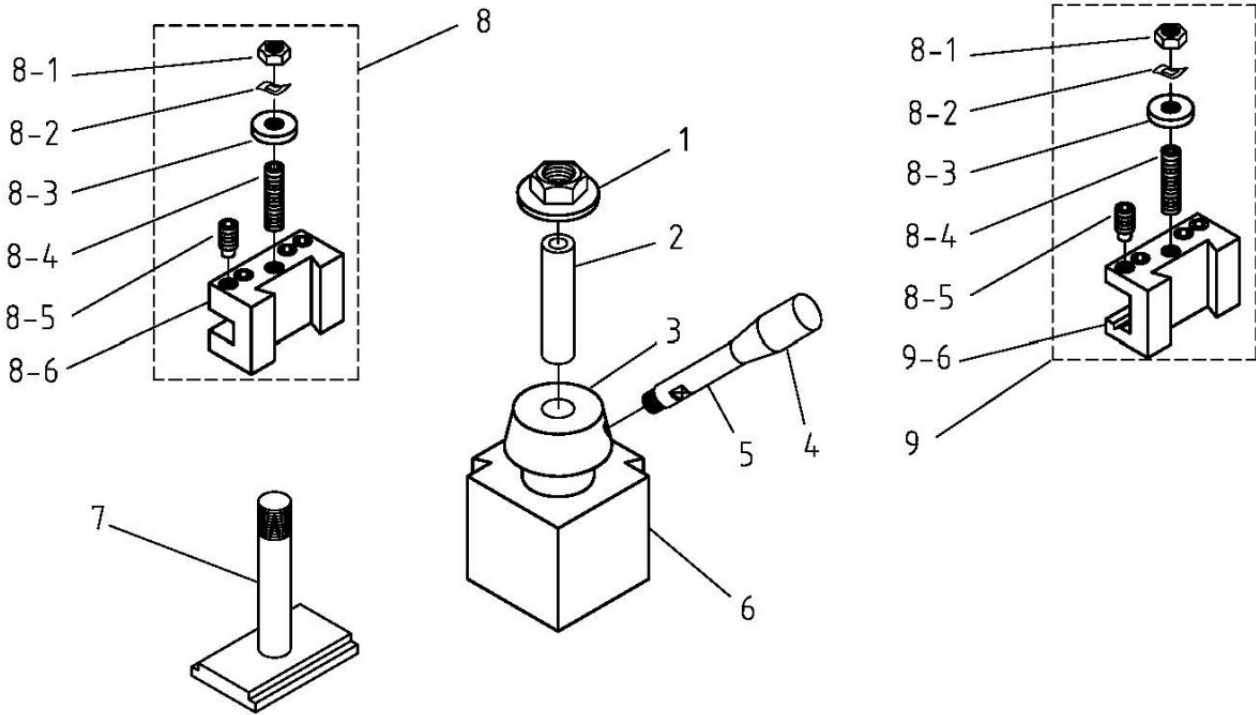

**QUICK CHANGE TOOLPOST (OPTIONAL) - PARTS LIST**

INDEX NO	PART NO	DESCRIPTION	SIZE	QTY
1		NUT	M16X1.5	1
2		WASHER		1
3		HUB		1
4	JB/T7271.3-M10	HANDLE	M10	1
5		LEVER		1
6		BODY		1
7		MOUNTING SHAFT		1
8		TURNING FACING HOLDER	16MM	1
8-1	GB/T6171	NUT	M10X1	2
8-2		WASHER	10	2
8-3		NUT	M10X1	2
8-4	GB/T77-M10X1X45	SCREW	M10X1X45	2
8-5	GB/T79-M10X20	SCREW	M10X20	4
8-6		TURNING FACING HOLDER		1
9		TURNING BORING FACING HOLDER	20MM	1
9-6		TURNING BORING FACING HOLDER		1

**NOTE: SOME INDIVIDUAL PARTS MAY ONLY BE AVAILABLE AS AN ASSEMBLY**

**DIGITAL READOUT - DIAGRAM**

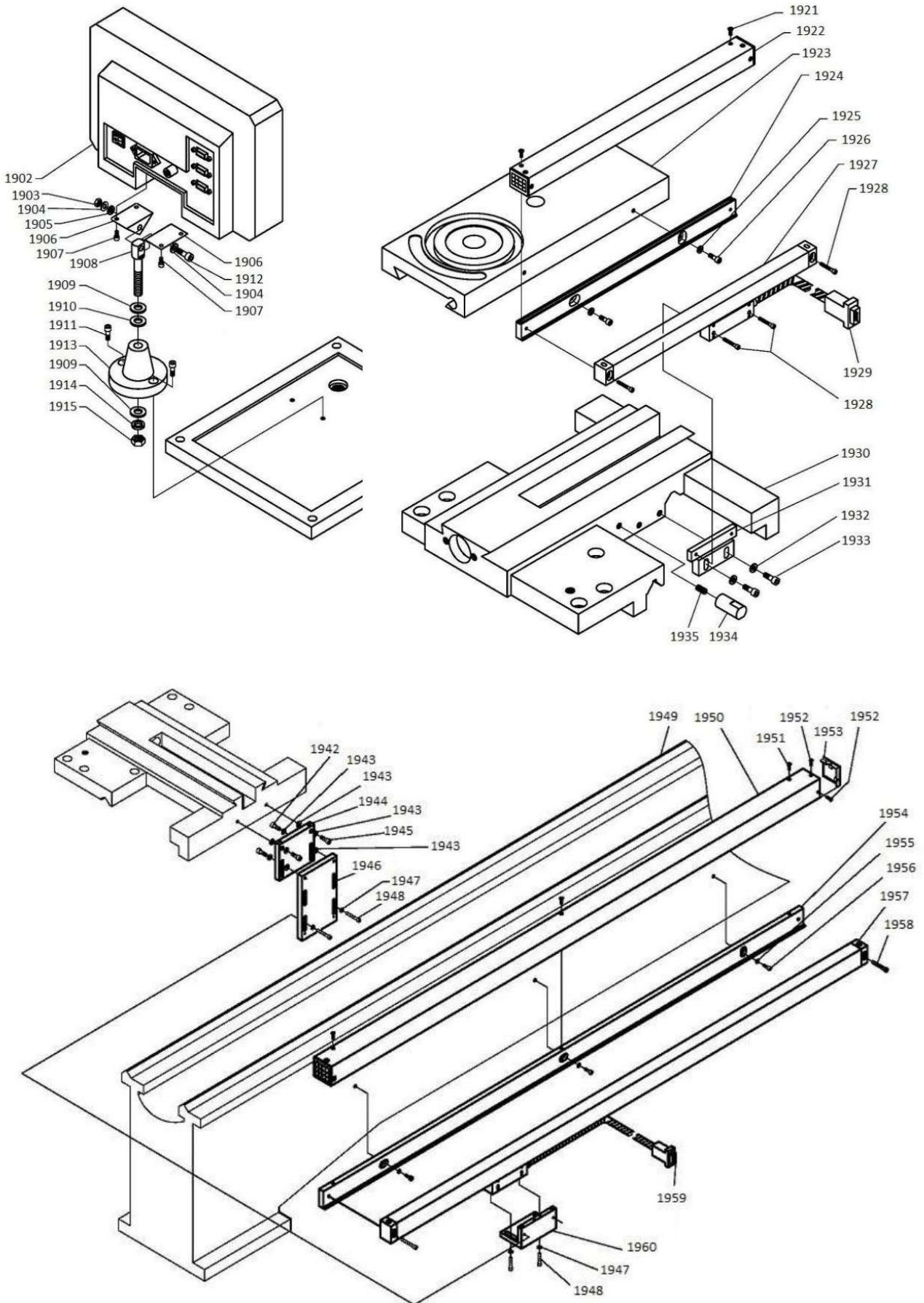

## DIGITAL READOUT - PARTS LIST

INDEX NO	PART NO	DESCRIPTION	SIZE	QTY
1902		DRO DISPLAY		1
1903	GB/T6170	HEX NUT	M6	1
1904	GB/T97.1	FLAT WASHER	6	2
1905	GB/T93	LOCK WASHER	6	1
1906		DISPLAY MOUNT PLATE		2
1907	GB/T70	HEX SOCKET CAP SCREW	M4X10	4
1908		DISPLAY MOUNT POST		1
1909	GB/T97.1	FLAT WASHER	10	2
1910		PLASTIC WASHER	10	1
1911	GB/T70	HEX SOCKET CAP SCREW	M5X14	2
1912	GB/T70	HEX SOCKET CAP SCREW	M6X30	1
1913		DISPLAY MOUNT BASE		1
1914	GB/T93	LOCK WASHER	10	1
1915	GB/T6170	NUT	M10	1
1921	GB/T819	SCREW	M3X6	2
1922		DRO CROSS SLIDE SENSOR COVER		1
1924		DRO CROSS SLIDE ADAPTER PLATE		1
1925	GB/T97.1	FLAT WASHER	4	2
1926	GB/T70	HEX SOCKET CAP SCREW	M4X12	2
1927		DRO POSITION SENSOR	220MM	1
1928	GB/T70	HEX SOCKET CAP SCREW	M3X20	4
1929		BNC CONNECTOR-KA500		1
1931		SADDLE ADAPTER PLATE		1
1932	GB/T97.1	FLAT WASHER	5	2
1933	GB/T70	HEX SOCKET CAP SCREW	M5X20	2
1934		HARD STOP		1
1935	GB/T73	SET SCREW	M6X15	1
1942	GB/T70	HEX SOCKET CAP SCREW	M5X25	2
1943	GB/T97.1	FLAT WASHER	5	8
1944		DRO ADAPTER PLATE		1
1945	GB/T70	HEX SOCKET CAP SCREW	M5X20	2
1946		DRO SENSOR PLATE		1
1947		THICK FLAT WASHER	4	4
1948	GB/T70	HEX SOCKET CAP SCREW	M4X20	4
1950		DRO POSITION SENSOR		1
1951	GB/T2673	SCREW	M4X6	3
1952	GB/T15856.1	SCREW	M6X30	2
1953		END CAP		2
1954		MOUNTING PLATE		1
1955		THICK FLAT WASHER	4	3
1956	GB/T70	HEX SOCKET CAP SCREW	M4X15	3
1957		DRO POSITION SENSOR	920MM	1
1958	GB/T70	HEX SOCKET CAP SCREW	M4X30	2
1959		BNC CONNECTOR-KA300		1
1960		ANGLE PLATE		1

**NOTE: SOME INDIVIDUAL PARTS MAY ONLY BE AVAILABLE AS AN ASSEMBLY**



#### **ENVIRONMENT PROTECTION**

Recycle unwanted materials instead of disposing of them as waste. All tools, accessories and packaging should be sorted, taken to a recycling centre and disposed of in a manner which is compatible with the environment. When the product becomes completely unserviceable and requires disposal, drain any fluids (if applicable) into approved containers and dispose of the product and fluids according to local regulations.

IMPORTED BY



Australian Distributor

**Hare & Forbes  
Machineryhouse**  
Sydney - Melbourne  
Adelaide - Brisbane - Perth

**Ph: 1300 202 200**  
[www.machineryhouse.com.au](http://www.machineryhouse.com.au)



New Zealand Distributor

**Machineryhouse**  
Auckland  
Christchurch

**Ph: 0800 142 326**  
[www.machineryhouse.co.nz](http://www.machineryhouse.co.nz)